

The Complete Homemade Juggling Beanbag Guide

Full Beanbag Pattern Compilation

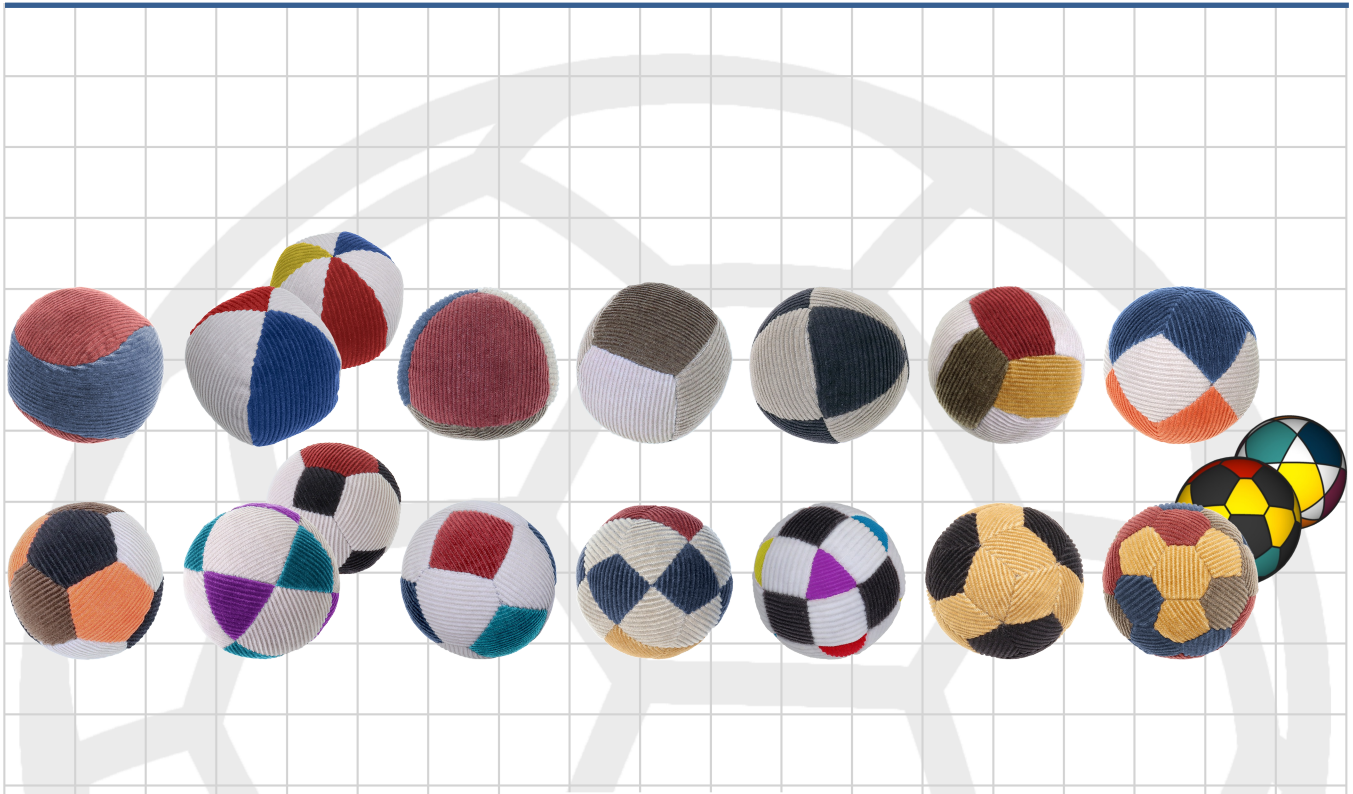

By Joshua Clifton

Contact me on Reddit under [Joshuacliftojm](#)
or at juggle@joshuaclifton.com

Published 5/20/2023

Last edited 10/8/2024

These patterns are from my instructional guide documents, which also include complete instructions for drawing the patterns and making the beanbags, as well as color arrangement ideas and supplementary beanbag information.

You can download the instructional guide PDFs at my website. And check there occasionally for revisions and corrections. Compare the Last Edited date above on the right with the one on the web page to see if I have submitted changes.

Please contact me with your thoughts!

Feedback on this project would be helpful and encouraging. You may also request custom patterns or other help with your project.

If these patterns are useful to you, please **consider donating at my website**. I am not monetizing the guide, and I am in need of income.

www.joshuaclifton.com/juggle

PATTERN INDEX

Printable Beanbag Measuring Tapes.....	4
2-Panel Baseball.....	5
4 & 6-Panel Orange Peel Ball/Beach Ball.....	10
4-Panel Spherical Tetrahedron.....	17
6-Panel Spherical Cube.....	21
8-Panel Spherical Octahedron.....	25
12-Panel Simplified Volleyball/Cube.....	29
12-Panel Spherical Dodecahedron.....	33
12-Panel Spherical Rhombic Dodecahedron.....	37
14-Panel Spherical Cuboctahedron & Truncated Octahedron....	41
14-Panel Spherical Equidistant Cuboctahedron.....	54
24-Panel Isovertex Deltoidal Icositetrahedron.....	60
26-Panel Rhombicuboctahedron.....	63
30-Panel Isovertex Rhombic Triacantahedron.....	68
32-Panel Equidistant Truncated Icosahedron and Variations.....	71

IMPORTANT NOTES:

Be sure to tell the Print Dialog to print only the page number(s) you want so you don't print the entire document.

The pattern pages are 8.27"×11" (210mm×279mm) to fit both "Letter" and "A4" sizes. **Make sure the print is not being scaled to fit the printer margins** (select Default/None scaling/Actual size/Ignore printer margins). To verify correct sizing, **compare the centimeter grid to a ruler** and adjust the next print if necessary. (Note that PDF viewers and printers can both contribute to slight size inaccuracy. The two setups I have used require 100.3% or 99.7% scaling for accurate sizing.)

The pattern images are 4500px × 5700px, 600dpi (7.5"×9.5"/190.5mm×241.3mm).

To produce other pattern sizes or correct an incorrectly sized beanbag, adjust the size scaling in the print dialog. For example, to reduce my 2.5" pattern to the 2.3" size

recommended by the Juggling Store for small hands and numbers juggling, divide 2.3 by 2.5, multiply the result by 100, and that is your scale (92% in this case). If your beanbag ends up not being the expected size, see the **General Information and Techniques** chapter under “[Adjusting/Scaling a Pattern to Produce an Accurate Ball Size](#)”¹ (in the *01 – Homemade Juggling Beanbag Guide – Index & Supplementary Chapters* document) for help with correcting it.

The table below provides the scaling for the 1/8" increments between my 1/4" sizes. The centimeter grid on each pattern page can be used to verify correct scaling.

1/8" Increment Scaling Table		
Target Diameter	Print this pattern size	At this scale
1 3/4" (44.5mm)	2"	87.5%
1 7/8" (47.6mm)	2"	93.8%
2 1/8" (54.0mm)	2 1/4"	94.4%
2 3/8" (60.3mm)	2 1/2"	95%
2 5/8" (66.7mm)	2 3/4"	95.4%
2 7/8" (73.0mm)	3"	95.8%

1 Link works only if you have the #01 guide root document in the same folder. **If the PDF does not open at the specified location**, keep it open, switch to this PDF’s tab, and click the link again. **Cross-document links may not work in mobile PDF readers.** In that case you must open the document yourself and find the linked topic. (Icon from <https://freesvg.org/vector-illustration-of-external-link-icon>.)

PRINTABLE BEANBAG MEASURING TAPES

This page is 8.27"×11" (210mm×279mm) to fit both "Letter" and "A4" sizes. **Make sure the print is not being scaled to fit the printer margins** (select Default/None scaling/Actual size/Ignore printer margins). **PDF viewers and printers can both contribute to slightly inaccurately sized prints. Compare the Circumference tapes to a ruler aligned at the bottom end and scale the next print if necessary.** My home prints come out slightly too small and so I have to print them at 100.3%. Prints at the library come out slightly too large and I have to print them at 99.7%.

Print and cut out these measuring tapes to measure your beanbags. **If your beanbags are not the size you expected, measuring them will enable you to calculate a corrected pattern size so that future beanbags will be the intended size.**

There are both metric (millimeter) and imperial (inch) tapes, and for each type there is one for measuring the circumference and one for measuring the diameter (its units are enlarged by a factor of π). Normally, to get a ball's diameter, you would measure the circumference and divide by π (3.1416). **The diameter tapes effectively divide by π for you.**

You can cut the tapes short for small balls. The end with the arrow must be intact, but the other end does not.

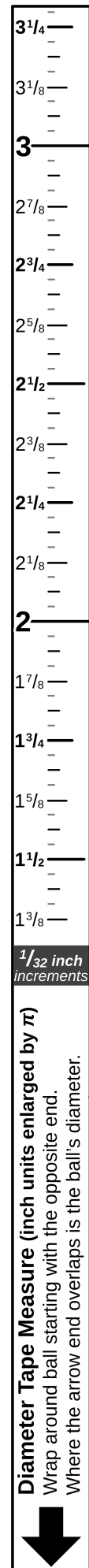
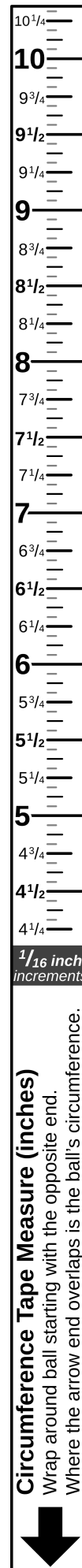
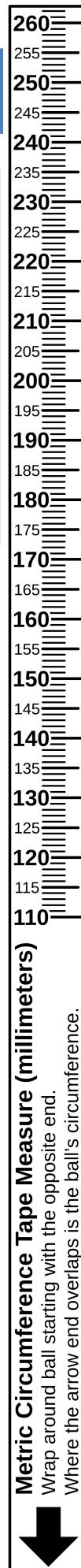

2-PANEL BASEBALL

[Back to Pattern Index](#)



On the following pages are patterns for beanbag diameters from 2" – 3" in $\frac{1}{4}$ " increments. The patterns are reduced by 5.77% from the mathematical calculation to account for the inflation in size I observed in my corduroy bag. **If you use a completely non-stretch fabric, I recommend enlarging the pattern to about 105% to get the intended ball size.**



To make the templates, I recommend cutting out the portions of the paper with the patterns you want and using glue or double-sided tape to attach them to your template material, and then cutting along the patterns.

The cutting patterns have 4mm, 6mm, and 8mm allowances so you can choose the amount that works best for your fabric and preference (the lighter, 6mm cutting pattern is a hair under $\frac{1}{4}$ "). Remember that the cutting patterns have slightly different proportions from the stitching patterns (they are parallel, not proportional), so **you should not use them as stitching patterns.**

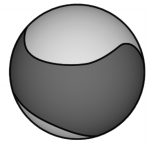
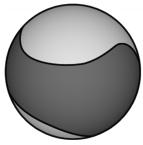

Baseball (2 Panels)

(Pattern sizes are adjusted for corduroy and do not account for gathered seams)

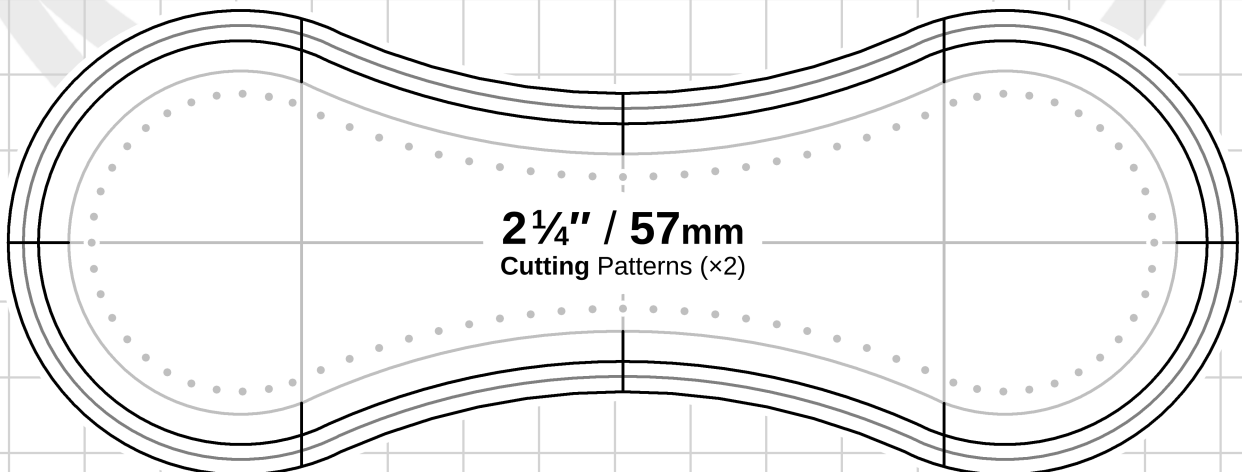
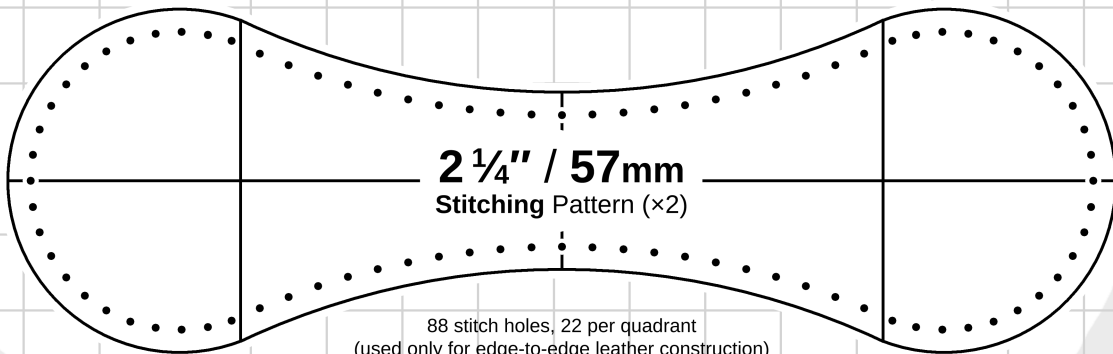
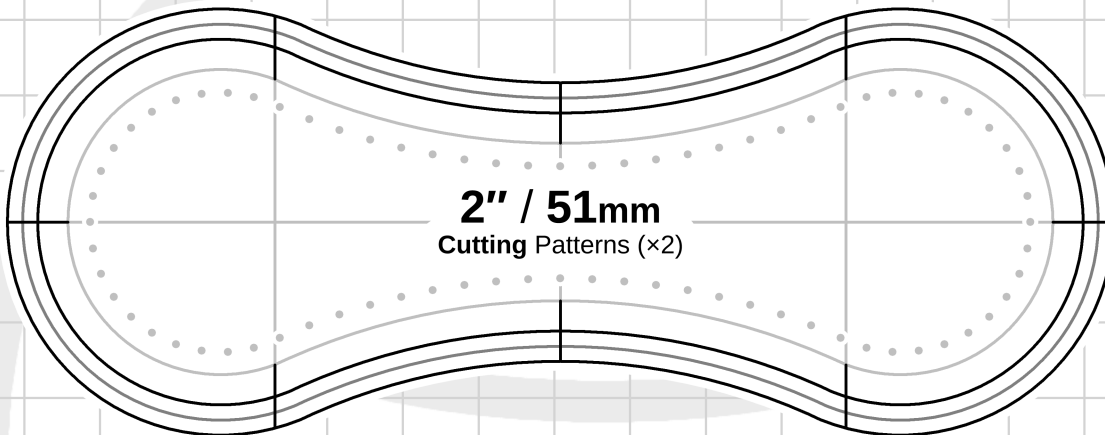
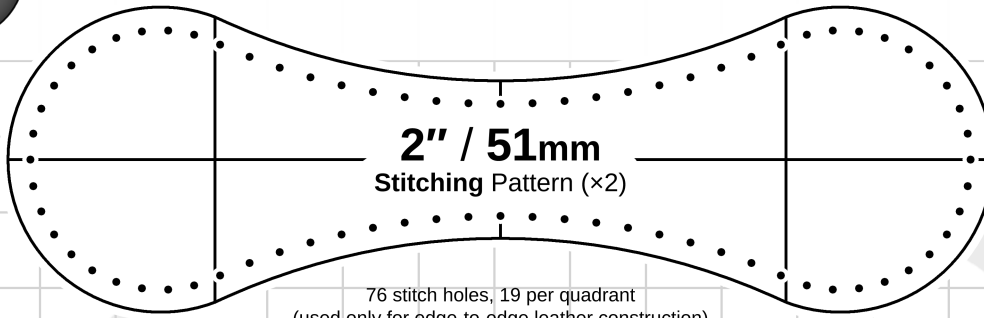

• • • **1mm awl holes for lacing leather balls**
(4mm spacing along pattern, but positioned inward along curve radii, 3mm from the edges, for correct spacing and alignment across joined convex and concave curves.)

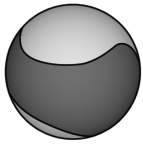

Baseball (2 Panels)

(Pattern sizes are adjusted for corduroy and do not account for gathered seams)

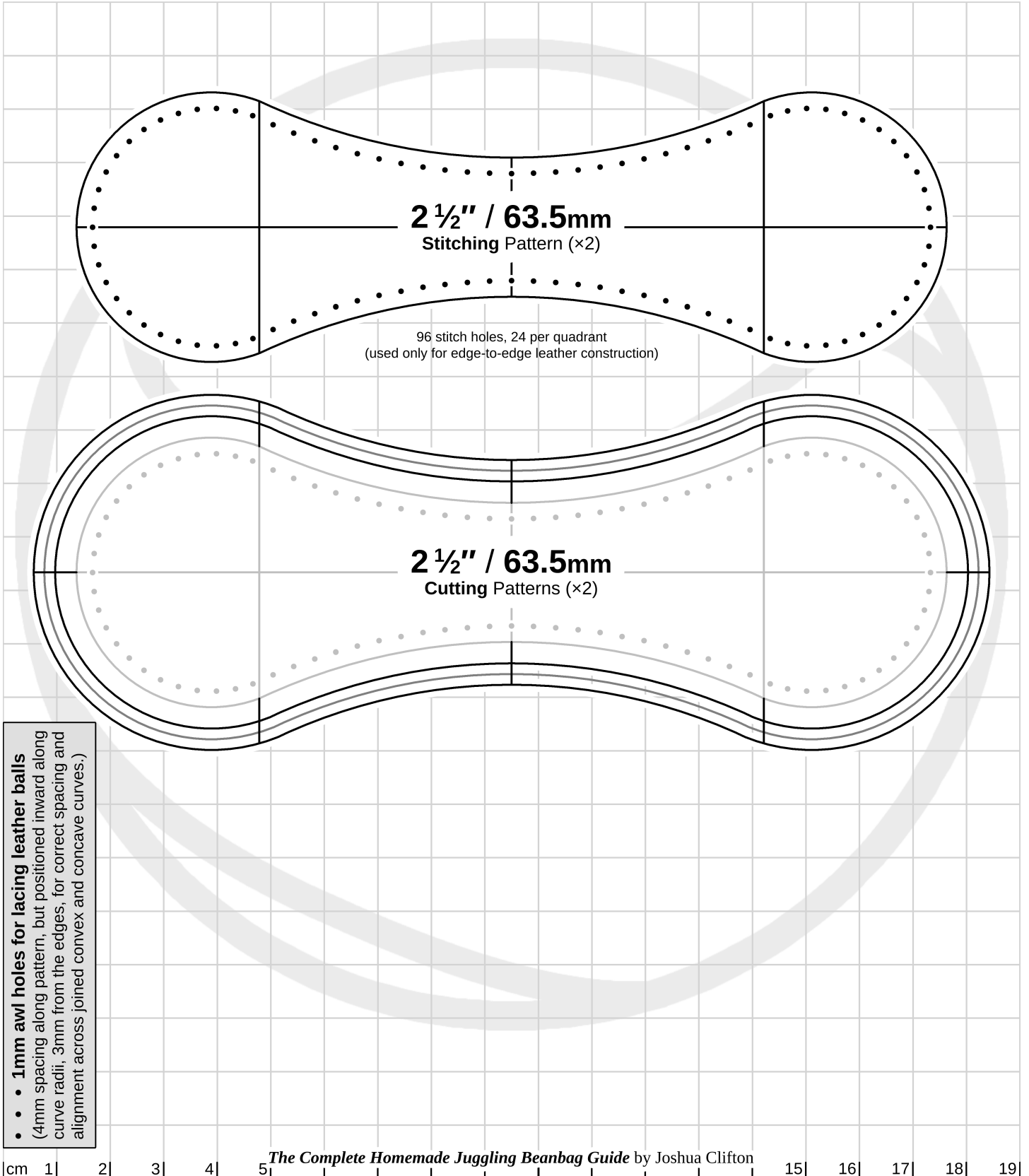
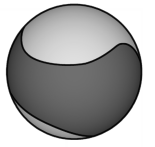

• • • 1mm awl holes for lacing leather balls
 (4mm spacing along pattern, but positioned inward along curve radii, 3mm from the edges, for correct spacing and alignment across joined convex and concave curves.)

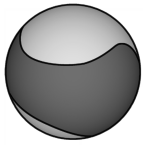

Baseball (2 Panels)

(Pattern sizes are adjusted for corduroy and do not account for gathered seams)

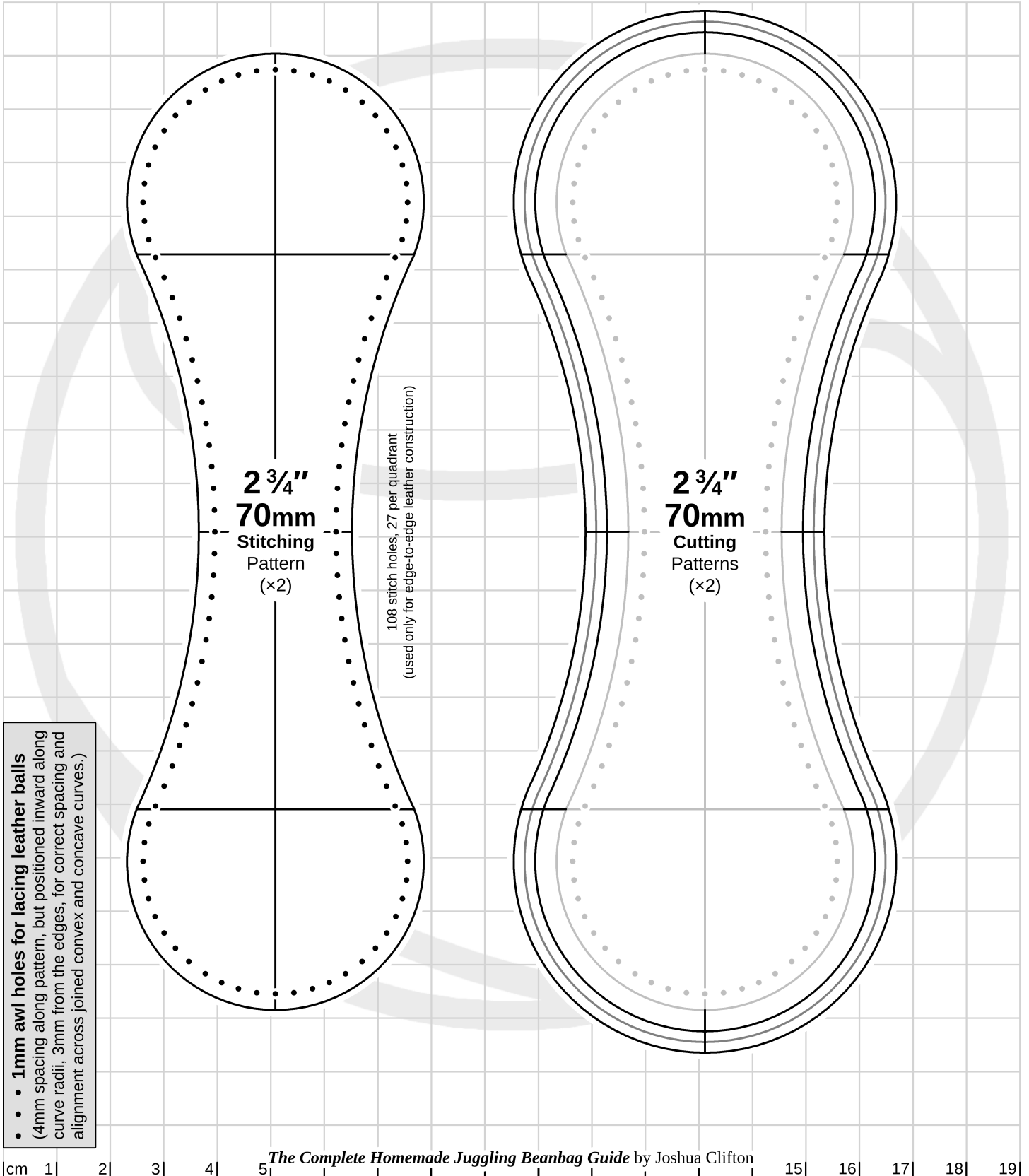
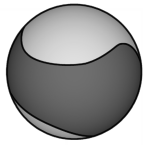

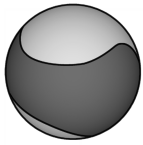

Baseball (2 Panels)

(Pattern sizes are adjusted for corduroy and do not account for gathered seams)

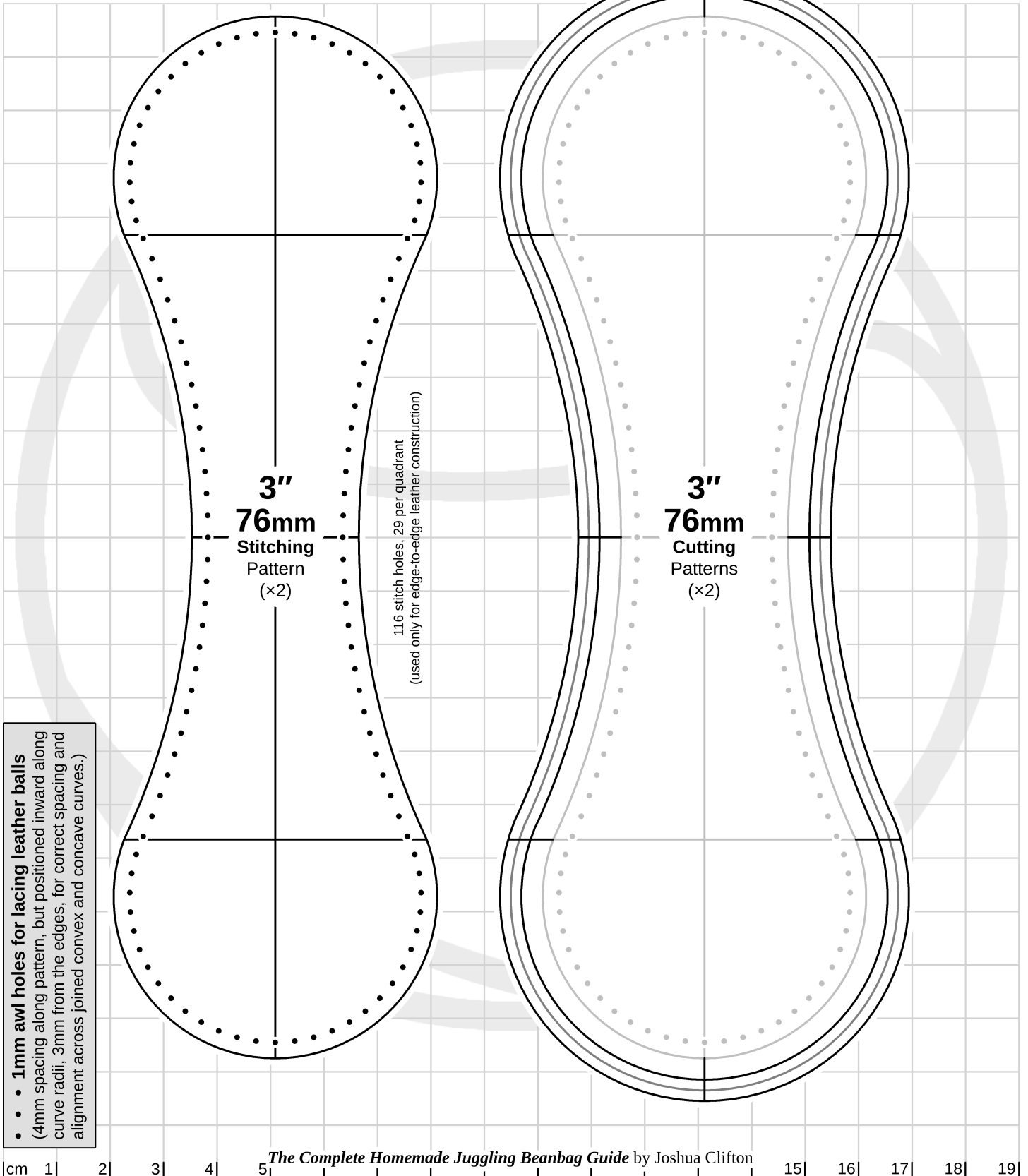
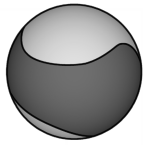

• • • 1mm awl holes for lacing leather balls
 (4mm spacing along pattern, but positioned inward along curve radii, 3mm from the edges, for correct spacing and alignment across joined convex and concave curves.)

116 stitch holes, 29 per quadrant
 (used only for edge-to-edge leather construction)

4 & 6-PANEL ORANGE PEEL BALL/BEACH BALL

[Back to Pattern Index](#)

On the following pages are 4-panel and 6-panel patterns for beanbag diameters from 2" – 3" in $\frac{1}{4}$ " increments, and 7" patterns for scaling to larger sizes. These patterns use my corrected curves, not circular curves. The patterns are reduced by 5.46% and 5.85%, respectively from the mathematical calculation to account for the inflation in size I observed in my



corduroy bag. **If you use a completely non-stretch fabric, I recommend enlarging the pattern to about 104% to get the intended ball size.**

To make the templates, I recommend cutting out the portions of the paper with the patterns you want and using glue or double-sided tape to attach them to your template material, and then cutting along the patterns.

The cutting patterns have 4mm, 6mm, and 8mm allowances so you can choose the amount that works best for your fabric and preference (the lighter, 6mm cutting pattern is a hair under $\frac{1}{4}$ "). Remember that the cutting patterns have slightly different proportions from the stitching patterns (they are parallel, not proportional), so **you should not use them as stitching patterns.**

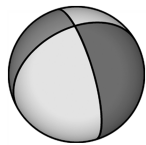

4-Panel Orange Peel Ball/Beach Ball

(Pattern sizes are adjusted for corduroy and do not account for gathered seams)

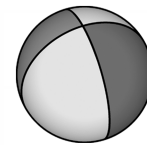

2"
51mm
Stitching
Pattern
(x4)

2 1/4"
57mm
Stitching
Pattern
(x4)

2 1/2"
63.5mm
Stitching
Pattern
(x4)

2"
51mm
Cutting
Patterns
(x4)

2 1/4"
57mm
Cutting
Patterns
(x4)

2 1/2"
63.5mm
Cutting
Patterns
(x4)

• • • 1mm awl holes for lacing leather balls
(4mm spacing, 3mm from edge)

cm 1 | 2 | 3 | 4 | 5 | *The Complete Homemade Juggling Beanbag Guide* by Joshua Clifton | 15 | 16 | 17 | 18 | 19

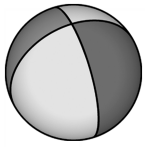

4-Panel Orange Peel Ball/Beach Ball

(Pattern sizes are adjusted for corduroy and do not account for gathered seams)

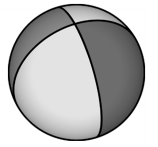

2 3/4"
70mm
Stitching
Pattern
(x4)

3"
76mm
Stitching
Pattern
(x4)

2 3/4"
70mm
Cutting
Patterns
(x4)

3"
76mm
Cutting
Patterns
(x4)

• • • 1mm awl holes for lacing leather balls
(4mm spacing, 3mm from edge)

cm 1 2 3 4 5 | *The Complete Homemade Juggling Beanbag Guide* by Joshua Clifton | 15 16 17 18 19

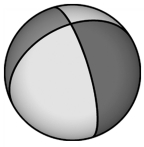

4-Panel Orange Peel Ball/Beach Ball

(Pattern sizes are adjusted for corduroy and do not account for...)

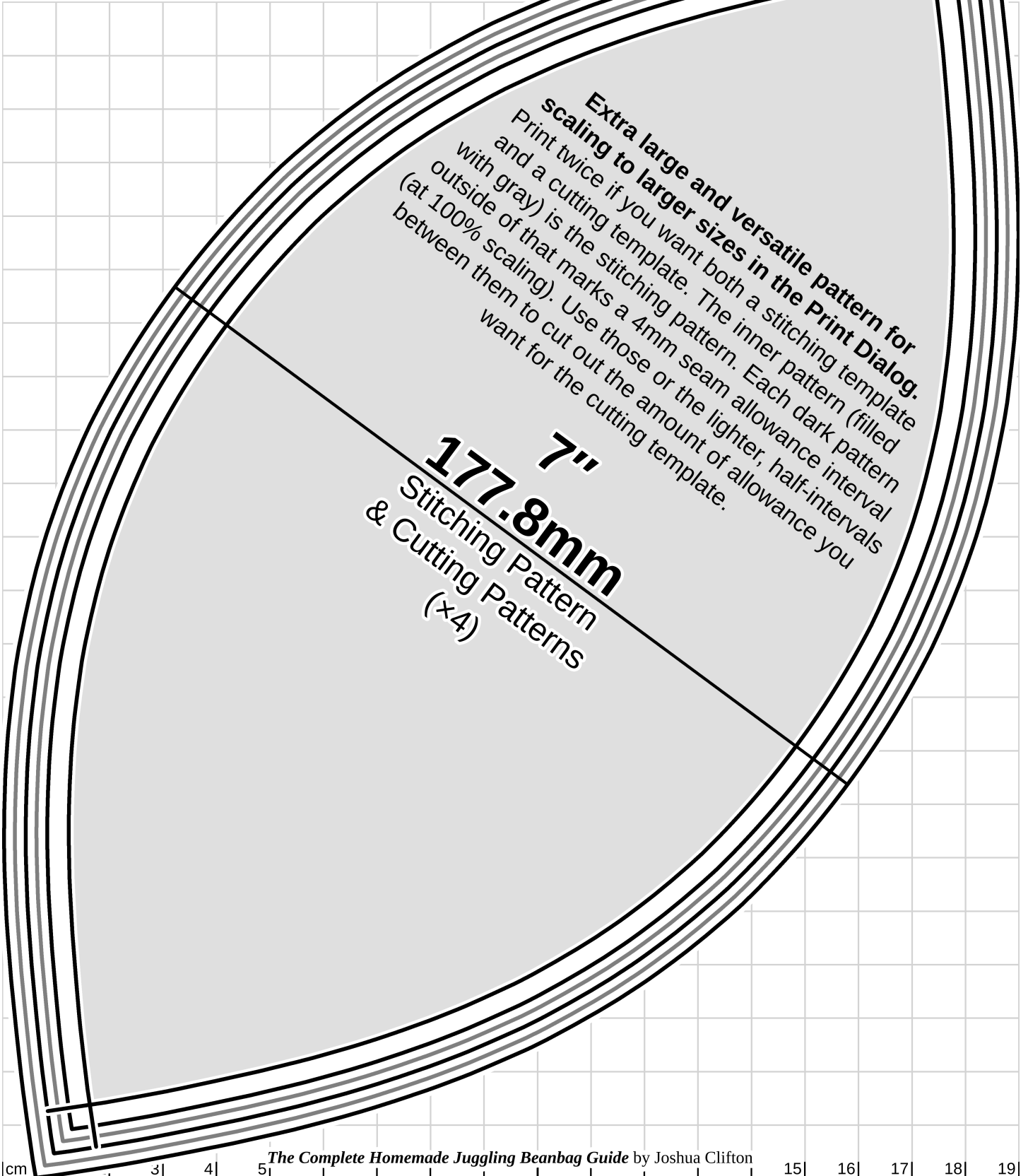

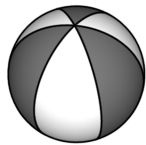

6-Panel Orange Peel Ball/Beach Ball

(Pattern sizes are adjusted for corduroy and do not account for gathered seams)

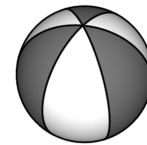

2" 51mm
Stitching Pattern (x6)

2 1/4" 57mm
Stitching Pattern (x6)

2 1/2" 63.5mm
Stitching Pattern (x6)

2" 51mm
Cutting Patterns (x6)

2 1/4" 57mm
Cutting Patterns (x6)

2 1/2" 63.5mm
Cutting Patterns (x6)

• • • 1mm awl holes for lacing leather balls (4mm spacing, 3mm from edge)

cm 1 2 3 4 5 15 16 17 18 19

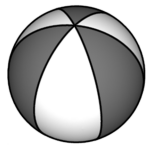

6-Panel Orange Peel Ball/Beach Ball

(Pattern sizes are adjusted for corduroy and do not account for gathered seams)

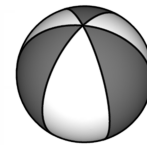

2 3/4" 70mm
Stitching
Pattern
(x6)

3" 76mm
Stitching
Pattern
(x6)

2 3/4" 70mm
Cutting
Patterns
(x6)

3" 76mm
Cutting
Patterns
(x6)

• • • •
1mm awl holes for lacing leather balls
(4mm spacing, 3mm from edge)

cm 1 2 3 4 5 15 16 17 18 19

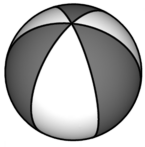

6-Panel Orange Peel Ball/Beach Ball

(Pattern sizes are adjusted for corduroy and do not account for gathered seams)

Extra large and versatile pattern for scaling to larger sizes in the Print Dialog. Print twice if you want both a stitching template and a cutting template. The inner pattern (filled with gray) is the stitching pattern. Each dark pattern outside of that marks a 4mm seam allowance interval (at 100% scaling). Use those or the lighter, half-intervals between them to cut out the amount of allowance you want for the cutting template.

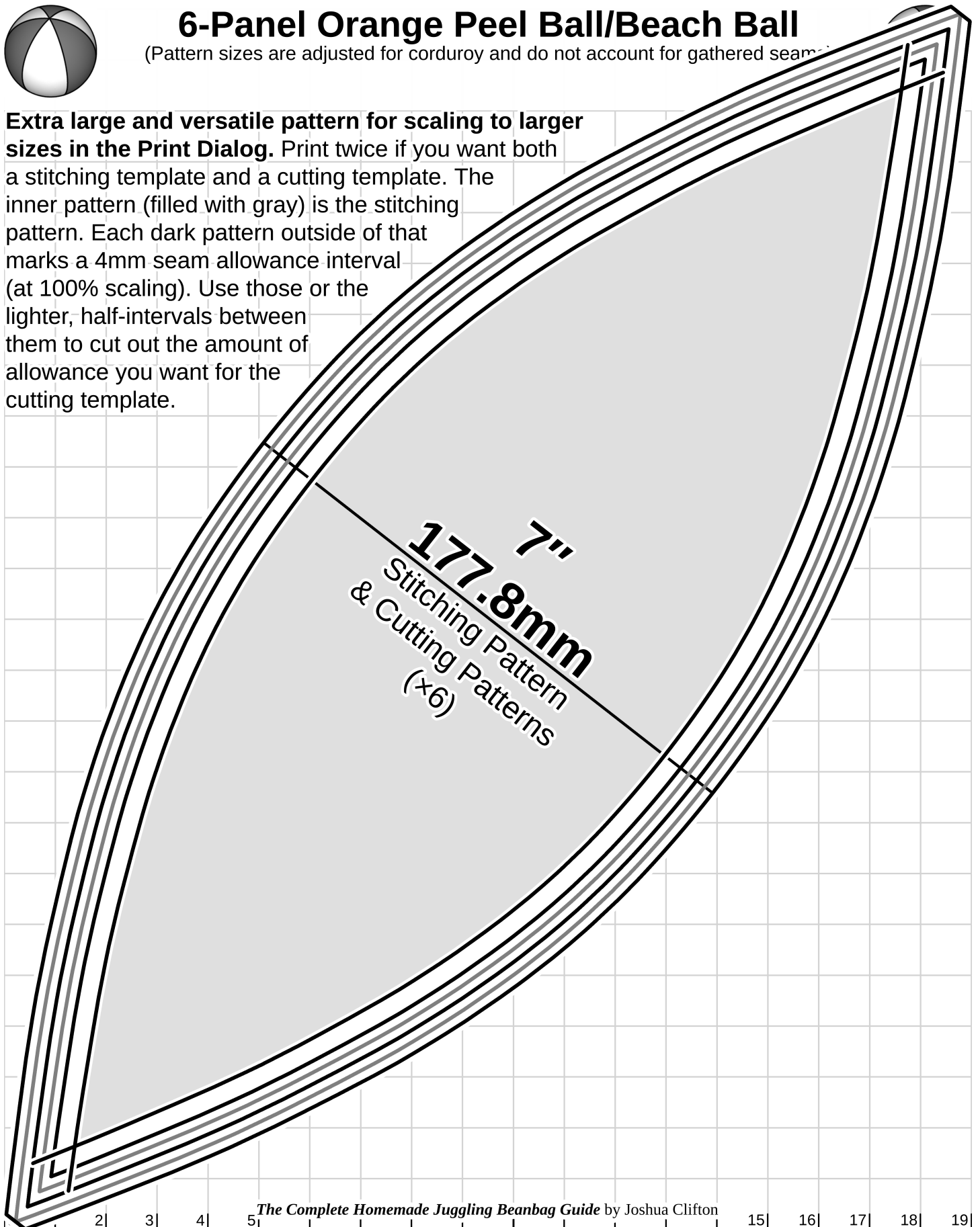

4-PANEL SPHERICAL TETRAHEDRON

[Back to Pattern Index](#)



On the following pages are patterns for beanbag diameters from 2" – 3" in $\frac{1}{4}$ " increments, and a 6" pattern for scaling to larger sizes. The patterns are reduced by 6.6% from the mathematical calculation to account for the inflation in size I observed in my corduroy bag. **If you use a completely non-stretch fabric, I recommend enlarging the pattern to about 103% to get the intended ball size.**

To make the templates, I recommend cutting out the portions of the paper with the patterns you want and using glue or double-sided tape to attach them to your template material, and then cutting along the patterns.

The cutting patterns have 4mm, 6mm, and 8mm allowances so you can choose the amount that works best for your fabric and preference (the lighter, 6mm cutting pattern is a hair under $\frac{1}{4}$ "). Remember that the cutting patterns have slightly different curve radius to panel size proportions from the stitching patterns (they are parallel, not proportional), so **you should not use them as stitching patterns.**

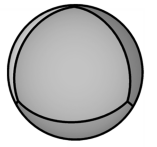
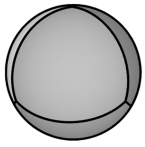

Tetrahedron (4 Panels)

(Pattern sizes are adjusted for corduroy and do not account for gathered seams)

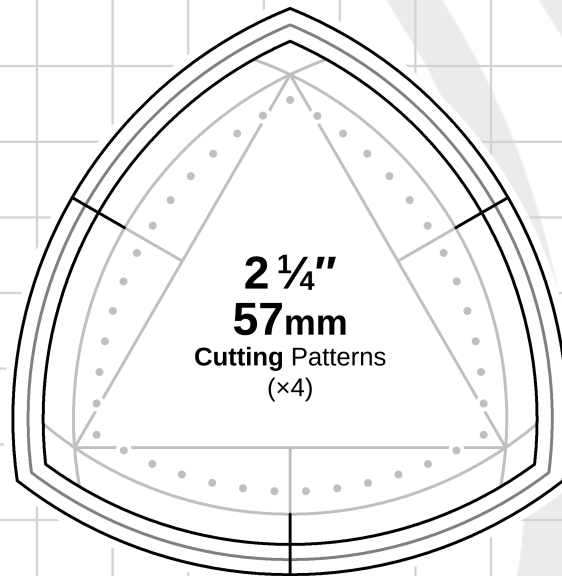
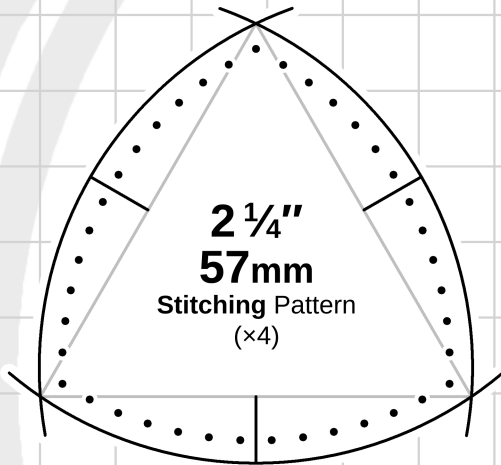
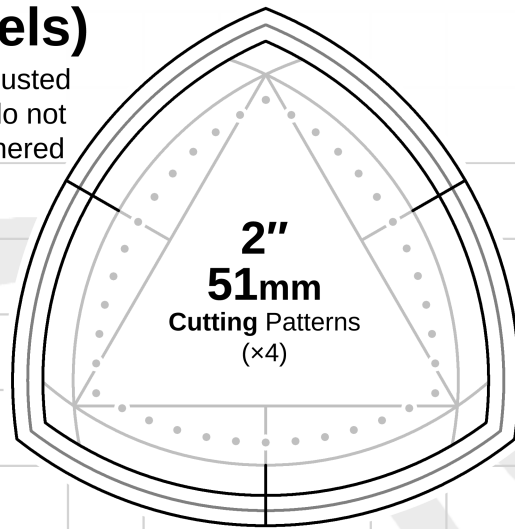
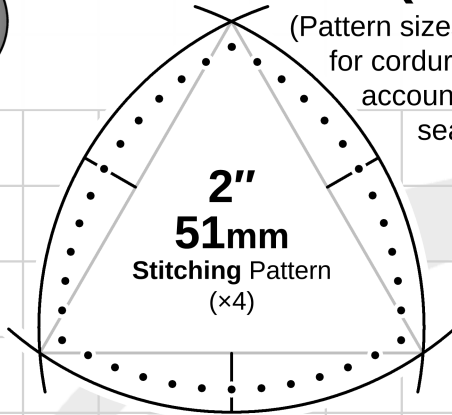

• • • 1mm awl holes for lacing leather (4mm spacing, 3mm from edge)

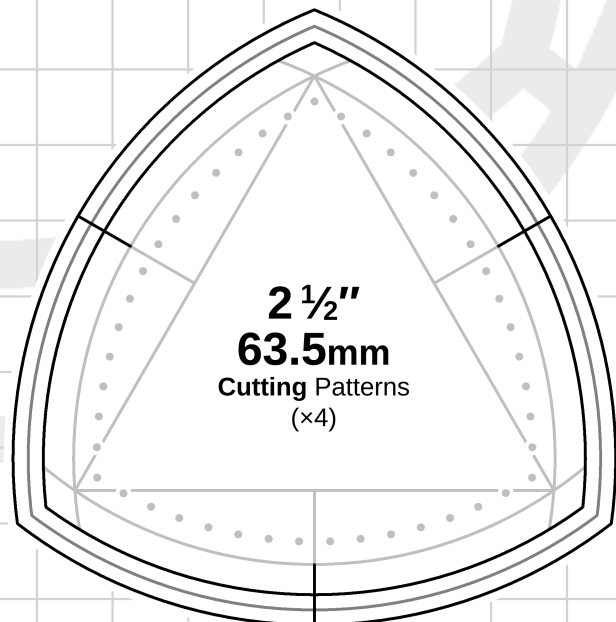
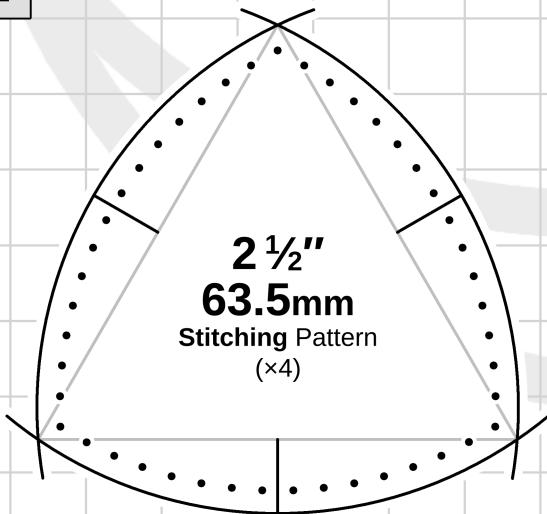

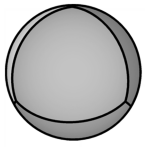

Tetrahedron (4 Panels)

(Pattern sizes are adjusted for corduroy and do not account for gathered seams)

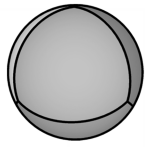

- • • 1mm awl holes for lacing leather (4mm spacing, 3mm from edge)

2 3/4"
70mm
Stitching Pattern
(x4)

2 3/4"
70mm
Cutting Patterns
(x4)

3"
76mm
Stitching Pattern
(x4)

3"
76mm
Cutting Patterns
(x4)

cm 1 | 2 | 3 | 4 | 5
The Complete Homemade Juggling Beanbag Guide by Joshua Clifton
15 | 16 | 17 | 18 | 19

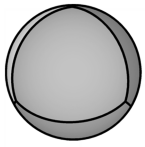

Tetrahedron (4 Panels)

(Pattern sizes are adjusted for corduroy and do not account for gathered seams)

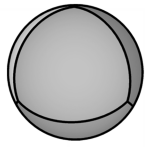

Extra large and versatile pattern for scaling to larger sizes in the Print Dialog. Print twice if you want both a stitching template and a cutting template. The inner pattern (filled with gray) is the stitching pattern. Each dark pattern outside of that marks a 4mm seam allowance interval (at 100% scaling). Use those or the lighter, half-intervals between them to cut out the amount of allowance you want for the cutting template.

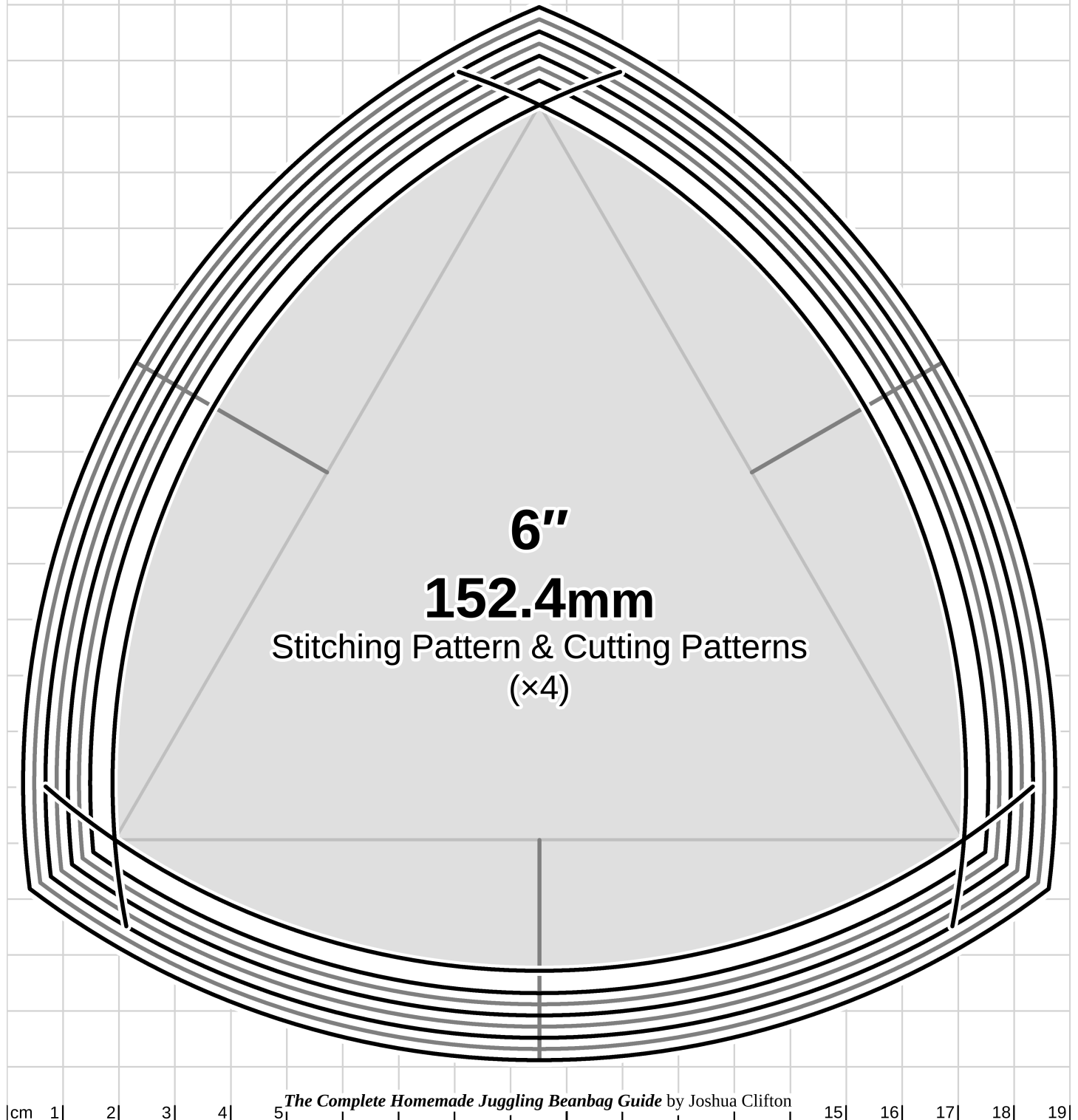

6-PANEL SPHERICAL CUBE

[Back to Pattern Index](#)



On the following pages are patterns for beanbag diameters from 2" – 3" in $\frac{1}{4}$ " increments, and a 7" pattern for scaling to larger sizes. The patterns are reduced by 7% from the mathematical calculation to account for the inflation in size I observed in my corduroy bag. **If you use a completely non-stretch fabric, I recommend enlarging the pattern to about 104% to get the intended ball size.**

To make the templates, I recommend cutting out the portions of the paper with the patterns you want and using glue or double-sided tape to attach them to your template material, and then cutting along the patterns.

The cutting patterns have 4mm, 6mm, and 8mm allowances so you can choose the amount that works best for your fabric and preference (the lighter, 6mm cutting pattern is a hair under $\frac{1}{4}$ "). Remember that the cutting patterns have slightly different curve radius to panel size proportions from the stitching patterns (they are parallel, not proportional), so **you should not use them as stitching patterns.**

To produce other pattern sizes or correct an incorrectly sized beanbag, adjust the size scaling in the print dialog. For example, to reduce my 2.5" pattern to the 2.3" size recommended by the Juggling Store for small hands and numbers juggling, divide 2.3 by 2.5, multiply the result by 100, and that is your scale (92% in this case). If your beanbag ends up not being the expected size, see the [General Information and Techniques](#) chapter under "[Adjusting/Scaling a Pattern to Produce an Accurate Ball Size](#)" for help with correcting it.

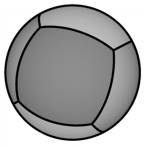

Cube (6 Panels)

(Pattern sizes are adjusted for corduroy and do not account for gathered seams)

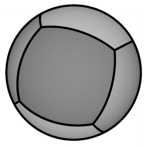

• • • 1mm awl holes for lacing leather balls
(4mm spacing, 3mm from edge)

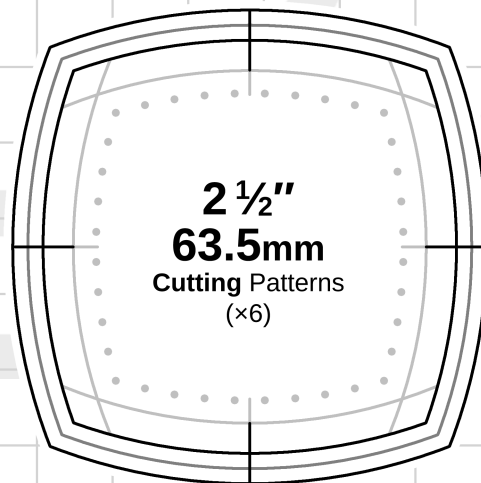
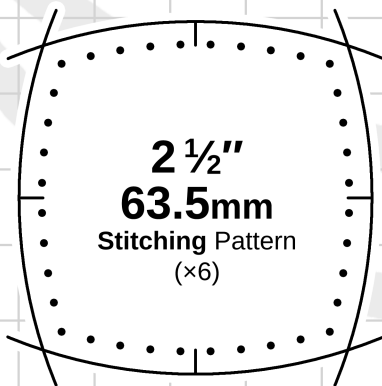
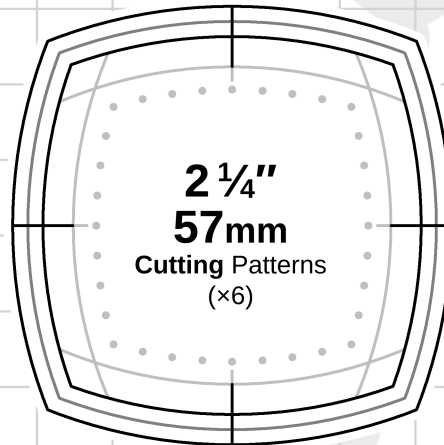
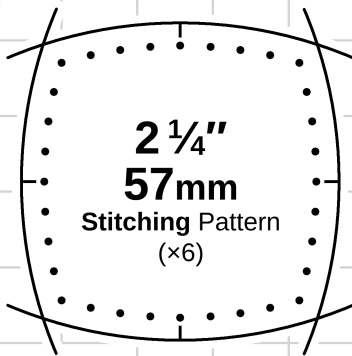
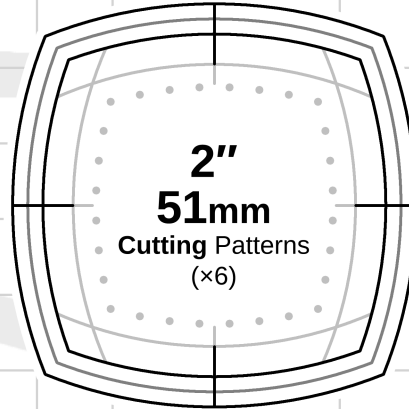
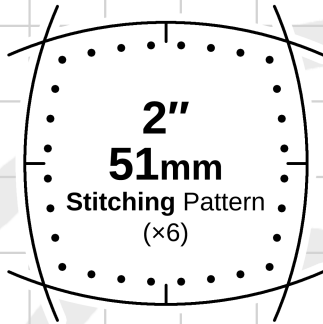

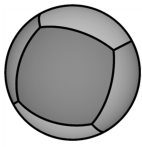

Cube (6 Panels)

(Pattern sizes are adjusted for corduroy and do not account for gathered seams)

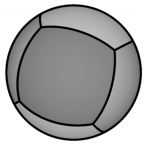

• • • 1mm awl holes for lacing leather balls
(4mm spacing, 3mm from edge)

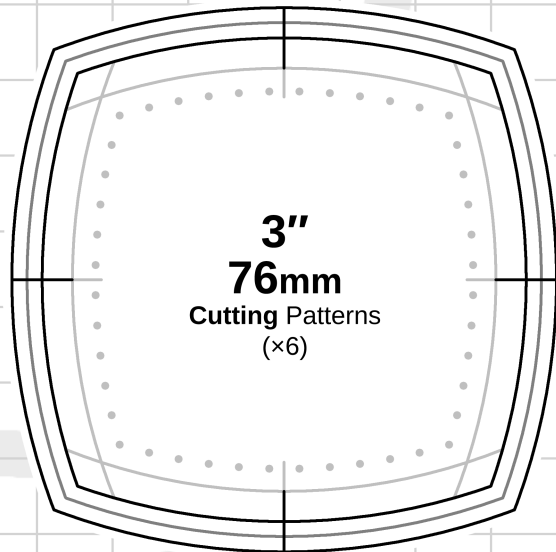
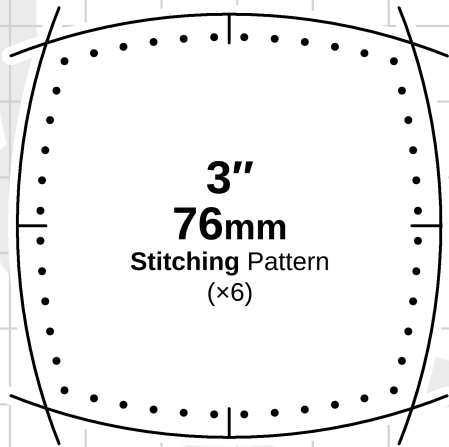
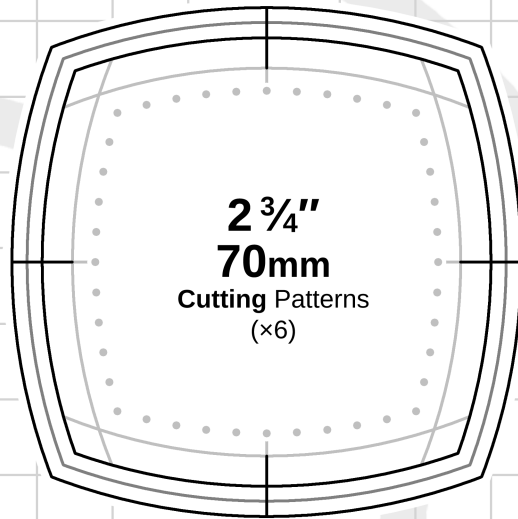
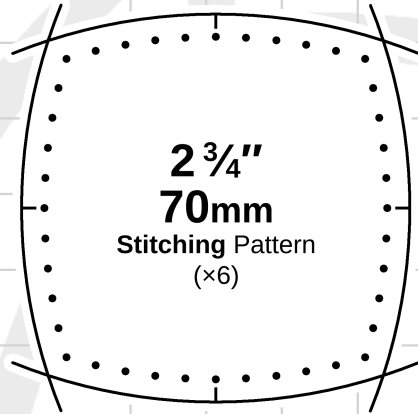

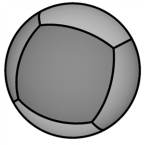

Cube (6 Panels)

(Pattern sizes are adjusted for corduroy and do not account for gathered seams)

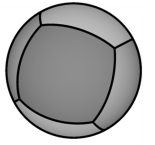

Extra large and versatile pattern for scaling to larger sizes in the Print Dialog. Print twice if you want both a stitching template and a cutting template. The inner pattern (filled with gray) is the stitching pattern. Each dark pattern outside of that marks a 4mm seam allowance interval (at 100% scaling). Use those or the lighter, half-intervals between them to cut out the amount of allowance you want for the cutting template.

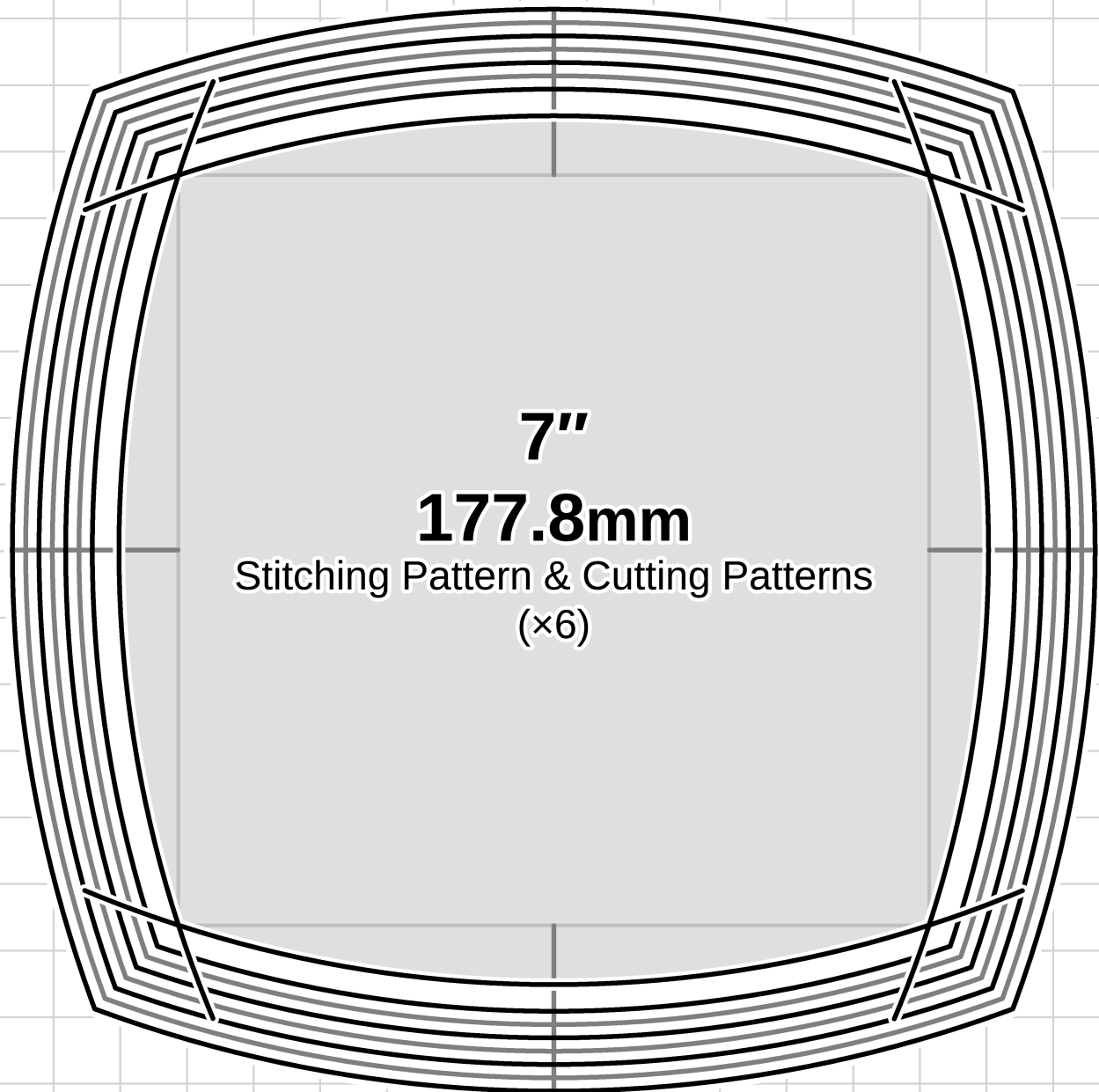

8-PANEL SPHERICAL OCTAHEDRON

[Back to Pattern Index](#)



On the following pages are patterns for beanbag diameters from 2" – 3" in $\frac{1}{4}$ " increments, and a 7" pattern for scaling to larger sizes. **These are my new Bézier curve patterns** (the cutting patterns are still circular, though). The patterns are reduced by 5% from the mathematical calculation to account for the inflation in size I observed in my corduroy bag. **If you use a completely non-stretch fabric, I recommend enlarging the pattern to about 101% to get the intended ball size.**

To make the templates, I recommend cutting out the portions of the paper with the patterns you want and using glue or double-sided tape to attach them to your template material, and then cutting along the patterns.

The cutting patterns have 4mm, 6mm, and 8mm allowances so you can choose the amount that works best for your fabric and preference (the lighter, 6mm cutting pattern is a hair under $\frac{1}{4}$ "). Remember that the cutting patterns have slightly different curve radius to panel size proportions from the stitching patterns (they are parallel, not proportional), so **you should not use them as stitching patterns.**



Octahedron (8 Panels)

(Pattern sizes are adjusted for corduroy and do not account for gathered seams.
The Stitching patterns use Bézier curves, the Cutting patterns are circular.)



• • • 1mm awl holes for lacing leather balls
(~4mm spacing, 3mm from edge)

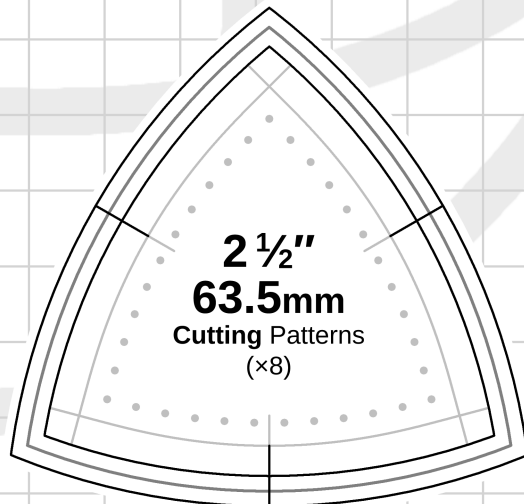
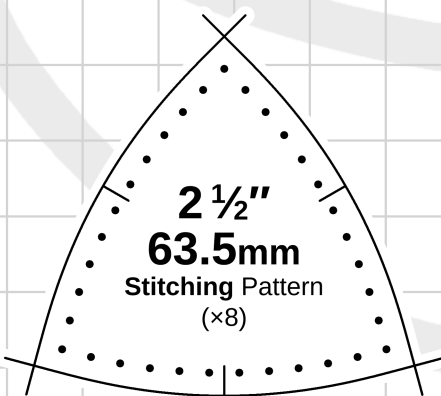
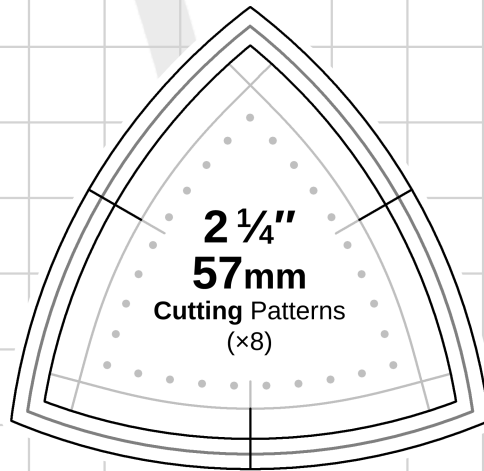
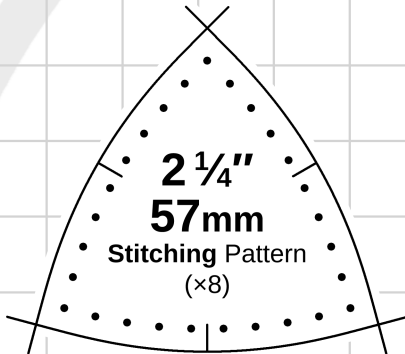
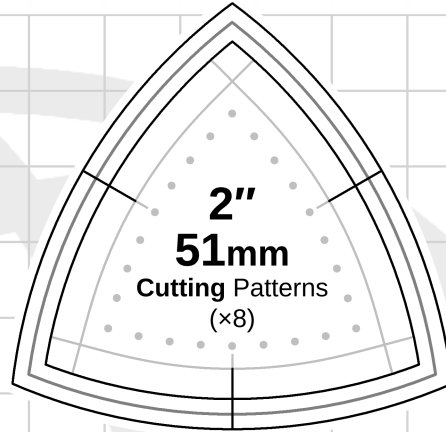
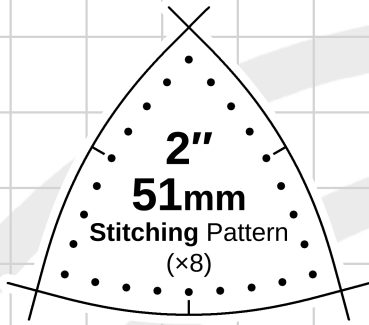



Octahedron (8 Panels)

(Pattern sizes are adjusted for corduroy and do not account for gathered seams.
The Stitching patterns use Bézier curves, the Cutting patterns are circular.)



• • • 1mm awl holes for lacing leather balls
(~4mm spacing, 3mm from edge)

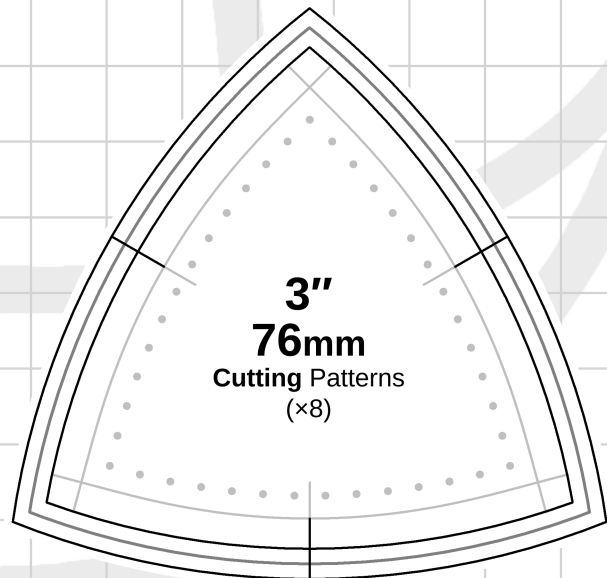
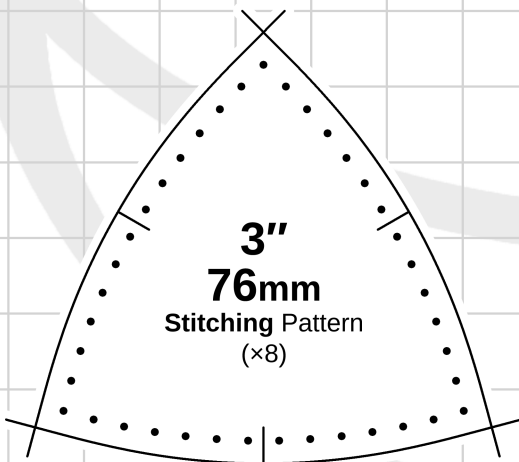
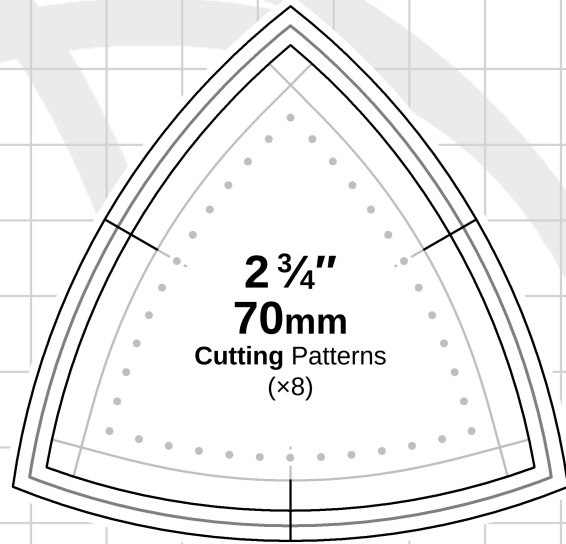
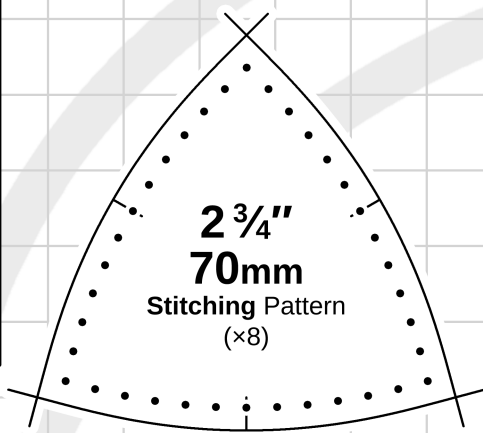



Octahedron (8 Panels)

(Pattern sizes are adjusted for corduroy and do not account for gathered seams.
The Stitching patterns use Bézier curves, the Cutting patterns are circular.)



Extra large and versatile pattern for scaling to larger sizes in the Print Dialog. Print twice if you want both a stitching template and a cutting template. The inner pattern (filled with gray) is the Bézier curve stitching pattern. Each dark pattern outside of that marks a 4mm seam allowance interval (at 100% scaling). Those patterns are circular. Use those or the lighter, half-intervals between them to cut out the amount of allowance you want for the cutting template.

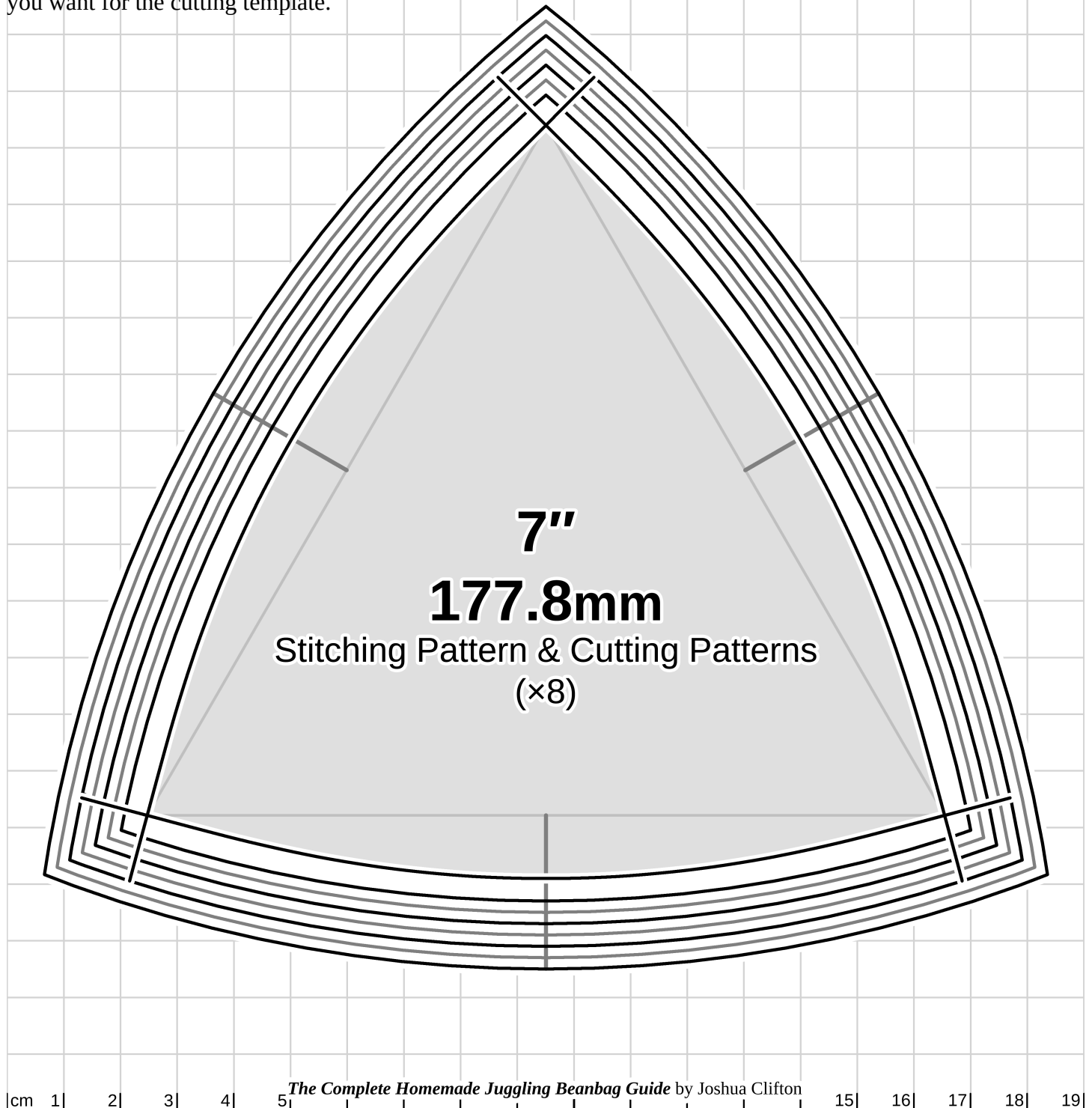

12-PANEL SIMPLIFIED VOLLEYBALL/CUBE

[Back to Pattern Index](#)



On the following pages are patterns for beanbag diameters from 2" – 3" in $\frac{1}{4}$ " increments, and a 7" pattern for scaling to larger sizes. The patterns are reduced by 6.3% from the mathematical calculation to account for the inflation in size I observed in my corduroy bag. **If you use a completely non-stretch fabric, I recommend enlarging the pattern to about 106% to get the intended ball size.**

To make the template, I recommend cutting out the portion of the paper with the pattern you want and gluing or taping it to your template material, and then cutting along the pattern.

The cutting patterns have 4mm, 6mm, and 8mm allowances so you can choose the amount that works best for your fabric and preference (the lighter, 6mm pattern is a hair under $\frac{1}{4}$ "), and they include **tabs for the optional combo type template** (stitching pattern on the inside, cutting pattern on the outside, with the tabs to help you hold it down). Two tabs may be sufficient with a rigid enough template.

The examples on the right show the **three ways you can cut out the Cutting/Combo templates** (using the 8mm allowance). Remember that the cutting patterns have slightly different curve radius to panel size proportions from the stitching patterns (they are parallel, not proportional), so you should not use them as stitching patterns.





Simplified Volleyball/Cube (12 Panels)

(Pattern sizes are adjusted for corduroy and do not account for gathered seams)

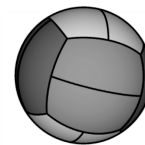

2" (51mm) Stitching Pattern

2 1/4" (57mm) Stitching Pattern

2" (51mm) Cutting/Combo Pattern

2 1/4" (57mm) Cutting/Combo Pattern

2 1/2" (63.5mm) Stitching Pattern

2 1/2" (63.5mm) Cutting/Combo Pattern

• • • 1mm awl holes for lacing leather balls (3.2-4.7mm spacing, 3mm from edge)

cm 1 | 2 | 3 | 4 | 5 | *The Complete Homemade Juggling Beanbag Guide* by Joshua Clifton | 15 | 16 | 17 | 18 | 19 |



Simplified Volleyball/Cube (12 Panels)

(Pattern sizes are adjusted for corduroy and do not account for gathered seams)

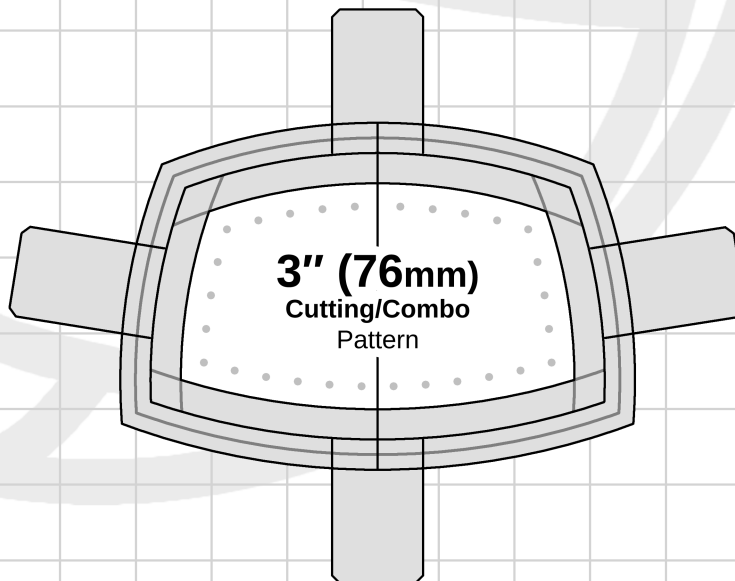
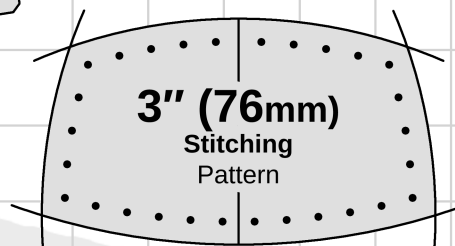
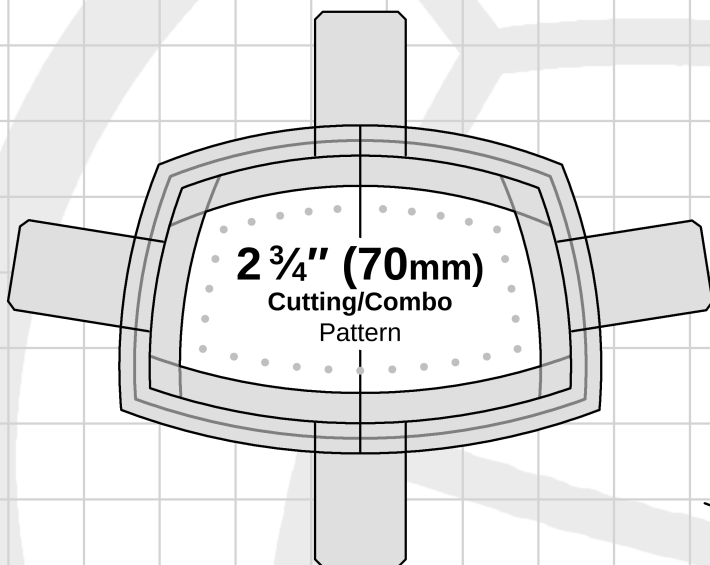
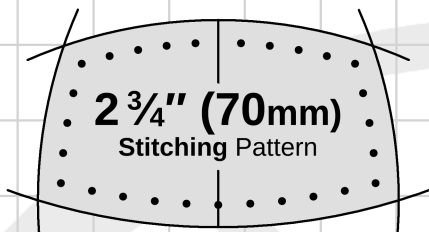
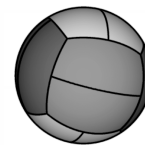

• • • 1mm awl holes for lacing leather balls
(3.2-4.7mm spacing, 3mm from edge)



Simplified Volleyball/Cube (12 Panels)

(Pattern sizes are adjusted for corduroy and do not account for gathered seams)

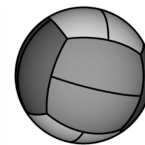

Extra large and versatile pattern for scaling to larger sizes in the Print Dialog. Print twice if you want both a stitching template and a cutting template. The inner pattern (filled with gray) is the stitching pattern. Each dark pattern outside of that marks a 4mm seam allowance interval (at 100% scaling). Use those or the lighter, half-intervals between them to cut out the amount of allowance you want for the cutting template.

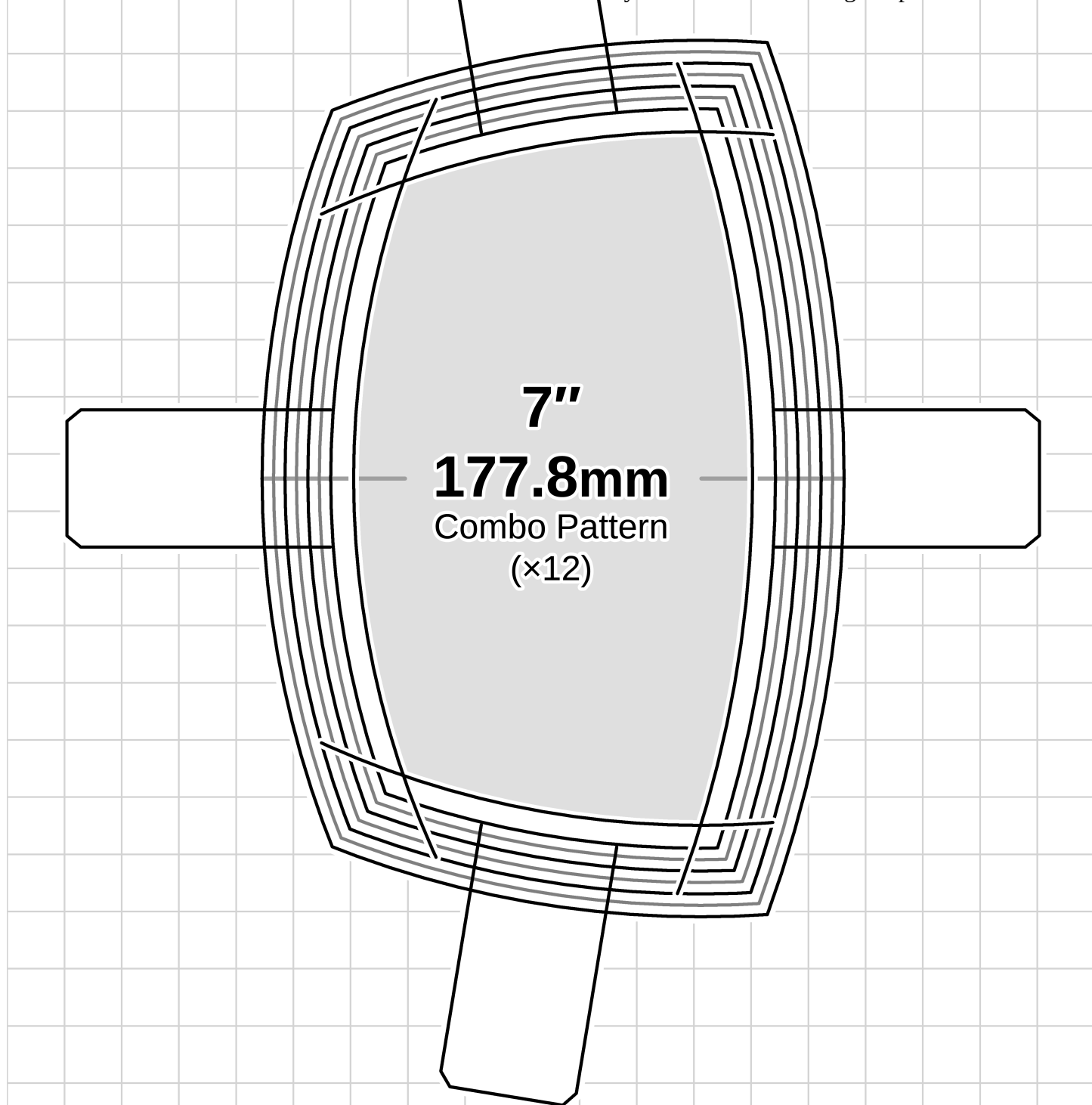

12-PANEL SPHERICAL DODECAHEDRON

[Back to Pattern Index](#)

On the following pages are patterns for beanbag diameters from 2" – 3" in $\frac{1}{4}$ " increments, and a 7" pattern for scaling to larger sizes. The patterns are reduced by 6.4% from the mathematical calculation to account for the inflation in size I observed in my corduroy bag. **If you use a dense/stiff or completely non-stretch fabric, I recommend enlarging the pattern to about 105% to get the intended ball size.**

To make the templates, I recommend cutting out the portions of the paper with the patterns you want and gluing or taping them to your template material, and then cutting along the patterns.

The cutting patterns have 4mm, 6mm, and 8mm allowances so you can choose the amount that works best for your fabric and preference (the lighter, 6mm pattern is a hair under $\frac{1}{4}$ "), and they include **tabs for the optional combo type template** (stitching pattern on the inside, cutting pattern on the outside, with the tabs to help you hold it down). Three tabs may be sufficient with a rigid template.

The examples on the right show the **three ways you can cut out the Cutting/Combo templates** (using the 8mm allowance).

Remember that the cutting patterns have slightly different curve radius to panel size proportions from the stitching patterns (they are parallel, not proportional), so you should not use them as stitching patterns.

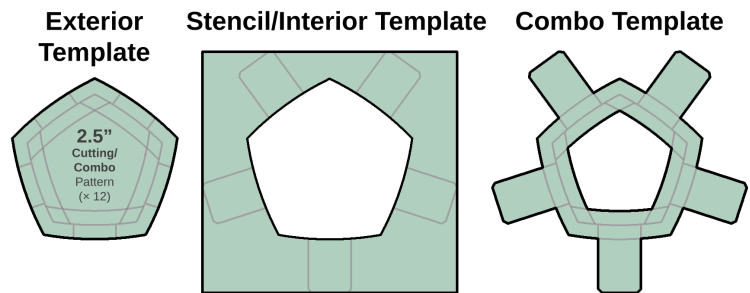

If you cut out these patterns as straight-edged pentagons (from corner to corner), the resulting beanbag will be about 97.5% the size of the circular-edged version. So to produce the same size, scale the printout to 102.8%.



Dodecahedron (12 Panels)

(Pattern sizes are adjusted for corduroy and do not account for gathered seams)

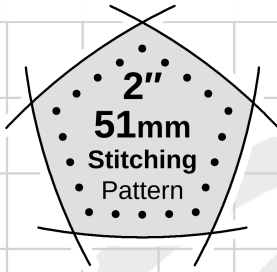

3.52mm awl hole spacing

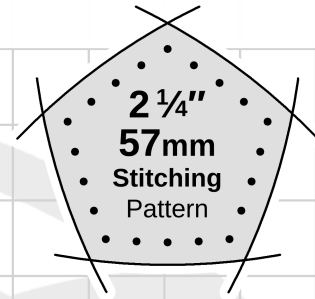
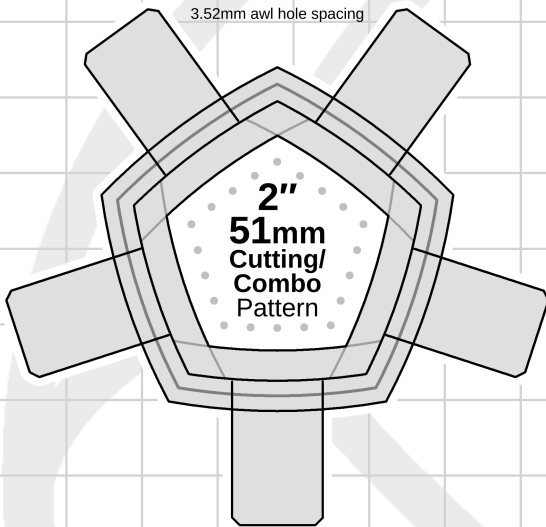

4.09mm awl hole spacing

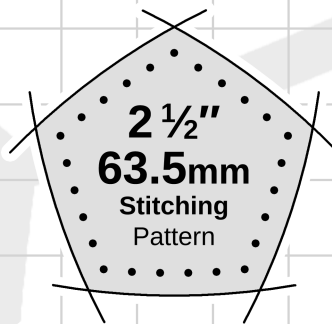
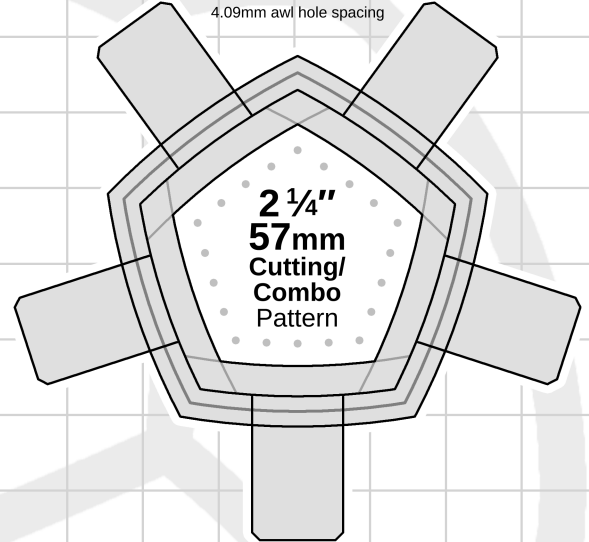

3.72mm awl hole spacing

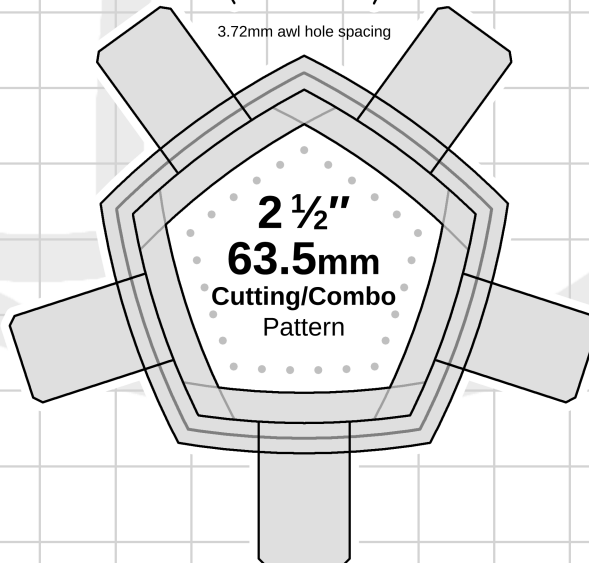

• • • 1mm awl holes for lacing leather balls
(3.5-4.2mm spacing, 3mm from edge)



Dodecahedron (12 Panels)

(Pattern sizes are adjusted for corduroy and do not account for gathered seams)

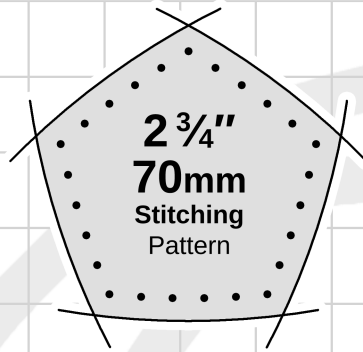

4.18mm awl hole spacing

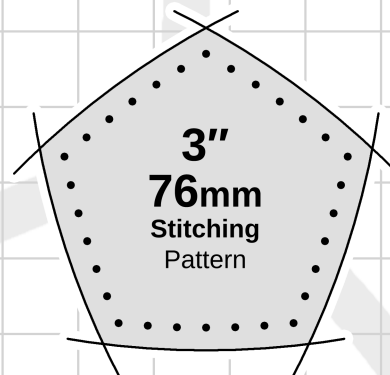
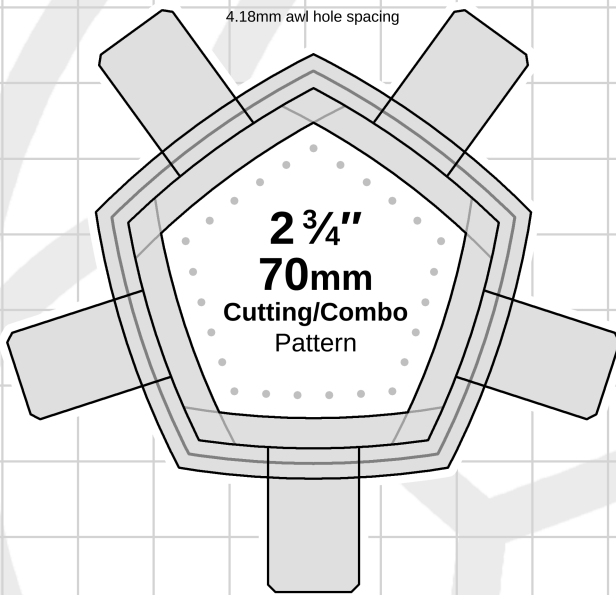

3.86mm awl hole spacing

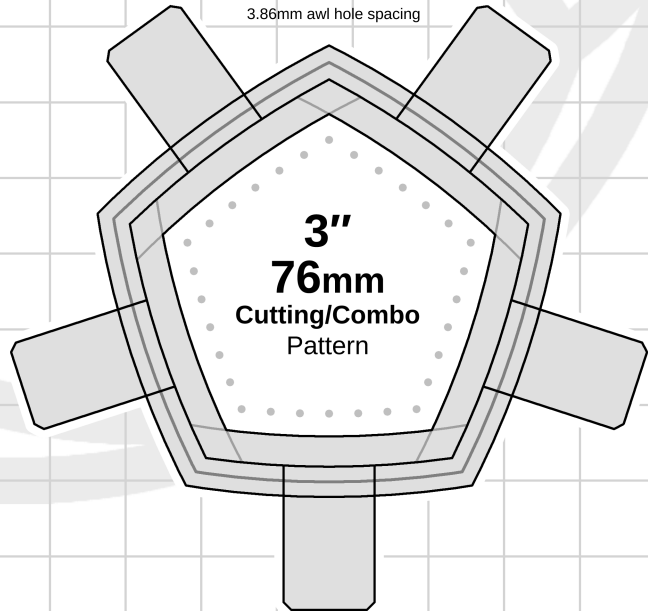

• • • 1mm awl holes for lacing leather balls
(3.5-4.2mm spacing, 3mm from edge)



Dodecahedron (12 Panels)

(Pattern sizes are adjusted for corduroy and do not account for gathered seams)



Extra large and versatile pattern for scaling to larger sizes in the Print Dialog. Print twice if you want both a stitching template and a cutting template (or cut out a combo template). The inner pattern (filled with gray) is the stitching pattern. Each dark pattern outside of that marks a 4mm seam allowance interval (at 100% scaling). Use those or the lighter, half-intervals between them to cut out the amount of allowance you want for the cutting template.

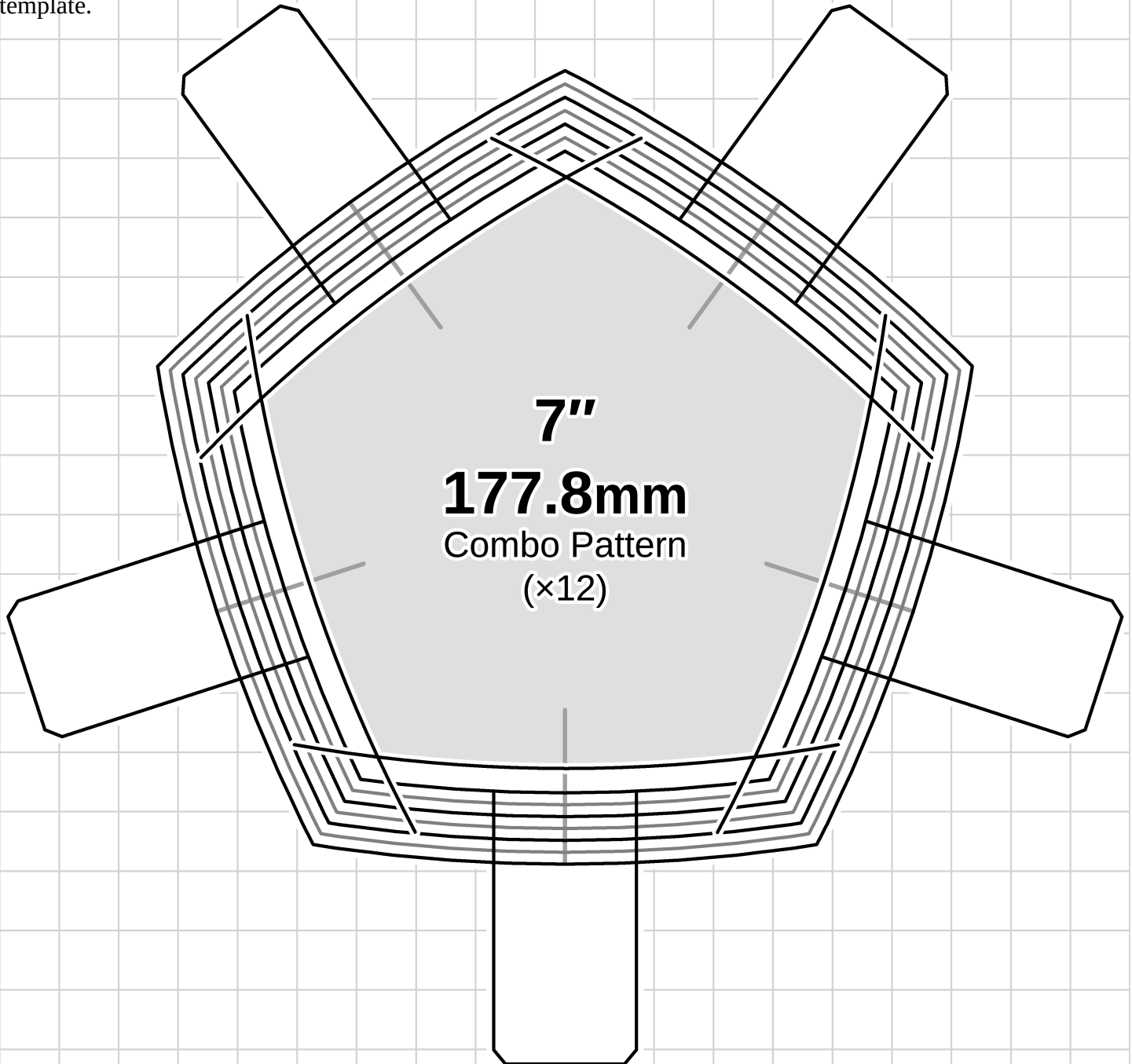

12-PANEL SPHERICAL RHOMBIC DODECAHEDRON

[Back to Pattern Index](#)

On the following pages are patterns for beanbag diameters from 2" – 3" in $\frac{1}{4}$ " increments, and a 7" pattern for scaling to larger sizes. The patterns are reduced by 2.73% from the mathematical calculation to account for the inflation in size I observed in my corduroy bag. **If you use a dense/stiff or completely non-stretch fabric, I recommend enlarging the pattern to about 103% to get the intended ball size.**

To make the template, I recommend cutting out the portion of the paper with the pattern you want and gluing or taping it to your template material, and then cutting along the pattern.

The cutting patterns have 4mm, 6mm, and 8mm allowances so you can choose the amount that works best for your fabric and preference (the lighter, 6mm pattern is a hair under $\frac{1}{4}$ "), and they include **tabs for the optional combo type template** (stitching pattern on the inside, cutting pattern on the outside, with the tabs to help you hold it down). Two tabs may be sufficient with a rigid enough template.

The examples on the right show the **three ways you can cut out the Cutting/Combo templates** (using the 8mm allowance).

Remember that the cutting patterns have slightly different curve radius to panel size proportions from the stitching patterns (they are parallel, not proportional), so you should not use them as stitching patterns.

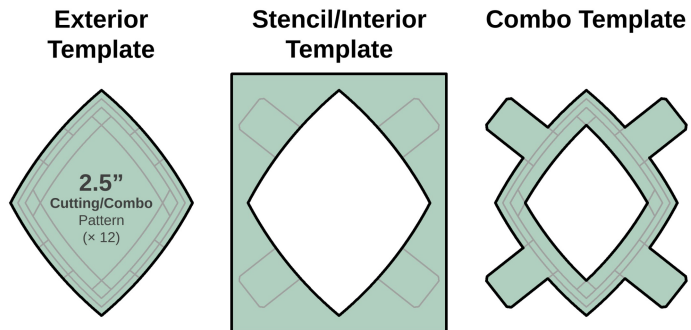



Rhombic Dodecahedron (12 panels)

(Pattern sizes are adjusted for corduroy and do not account for gathered seams)



2"
51mm
Stitching
Pattern
(x12)

2 1/4"
57mm
Stitching
Pattern
(x12)

2"
51mm
Cutting/Combo
Pattern
(x12)

2 1/2"
63.5mm
Stitching
Pattern
(x12)

2 1/4"
57mm
Cutting/Combo
Pattern
(x12)

2 1/2"
63.5mm
Cutting/Combo
Pattern
(x12)

cm 1 2 3 4 5 *The Complete Homemade Juggling Beanbag Guide* by Joshua Clifton 15 16 17 18 19



Rhombic Dodecahedron (12 panels)

(Pattern sizes are adjusted for corduroy and do not account for gathered seams)



2 3/4"
70mm
Stitching
Pattern
(×12)

3"
76mm
Stitching
Pattern
(×12)

2 3/4"
70mm
Cutting/Combo
Pattern
(×12)

3"
76mm
Cutting/Combo
Pattern
(×12)

cm 1 2 3 4 5 15 16 17 18 19

The Complete Homemade Juggling Beanbag Guide by Joshua Clifton



Rhombic Dodecahedron (12 panels)

(Pattern sizes are adjusted for corduroy and do not account for gathered seams)



Extra large and versatile pattern for scaling to larger sizes in the Print Dialog. Print twice if you want both a stitching template and a cutting template (or cut out a combo template). The inner pattern (filled with gray) is the stitching pattern. Each dark pattern outside of that marks a 4mm seam allowance interval (at 100% scaling). Use those or the lighter, half-intervals between them to cut out the amount of allowance you want for the cutting template.

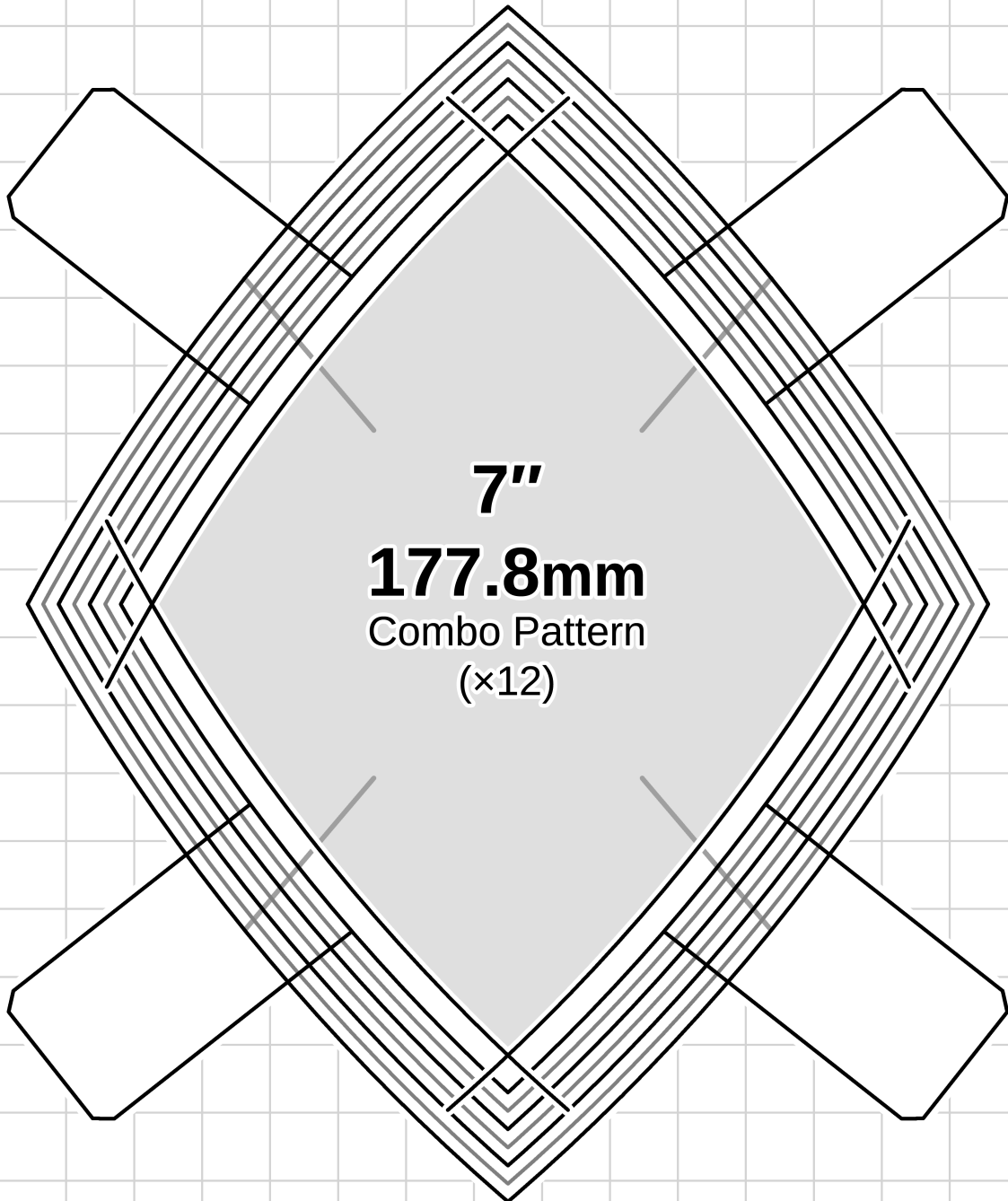

14-PANEL SPHERICAL CUBOCTAHEDRON & TRUNCATED OCTAHEDRON

[Back to Pattern Index](#)

The **Cuboctahedron patterns** (triangles and squares) begin on the next page. Those are followed by the **Truncated Octahedron Patterns** (hexes and squares). The patterns are for beanbag diameters from 2" – 3" in $\frac{1}{4}$ " increments, and there are 7" patterns for scaling to larger sizes. The Cuboctahedron patterns are reduced by 5.87% and the Truncated Octahedron



by 4.66% from the mathematical calculations to account for the inflation in size I observed in my corduroy bags. **If you use a dense/stiff or completely non-stretch fabric, I recommend enlarging the pattern to about 105% to get the intended ball size.**

To make the templates, I recommend cutting out the portions of the paper with the patterns you want and gluing or taping them to your template material, and then cutting along the patterns.

The cutting patterns have 4mm, 6mm, and 8mm allowances so you can choose the amount that works best for your fabric and preference (the lighter, 6mm pattern is a hair under $\frac{1}{4}$ "), and they include **tabs for the optional combo type template** (stitching pattern on the inside, cutting pattern on the outside, with the tabs to help you hold it down). The hex's small tabs may not be needed.

The examples on the right show the **three ways you can cut out the Cutting/Combo templates** (using the 8mm allowance). Remember that the cutting patterns have slightly different proportions from the stitching patterns (they are parallel, not proportional), so you should not use them as stitching patterns. **You can cut out the Truncated Octahedron patterns as straight-edged templates and still get a perfectly good sphere, but it will be about 2% smaller.**

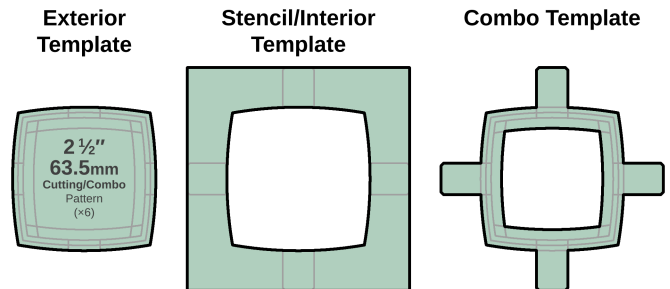



Cuboctahedron (14 panels)

(Pattern sizes are adjusted for corduroy and do not account for gathered seams)



2"
51mm
Stitching
Pattern (x6)

2"
51mm
Stitching
Pattern (x8)

2"
51mm
Cutting/Combo
Pattern (x6)

2"
51mm
Cutting/Combo
Pattern (x8)

2 1/4"
57mm
Stitching
Pattern (x6)

2 1/4"
57mm
Stitching
Pattern (x8)

2 1/4"
57mm
Cutting/Combo
Pattern (x8)

2 1/4"
57mm
Cutting/Combo
Pattern (x6)

cm 1 2 3 4 5 15 16 17 18 19

The Complete Homemade Juggling Beanbag Guide by Joshua Clifton



Cuboctahedron (14 panels)

(Pattern sizes are adjusted for corduroy and do not account for gathered seams)

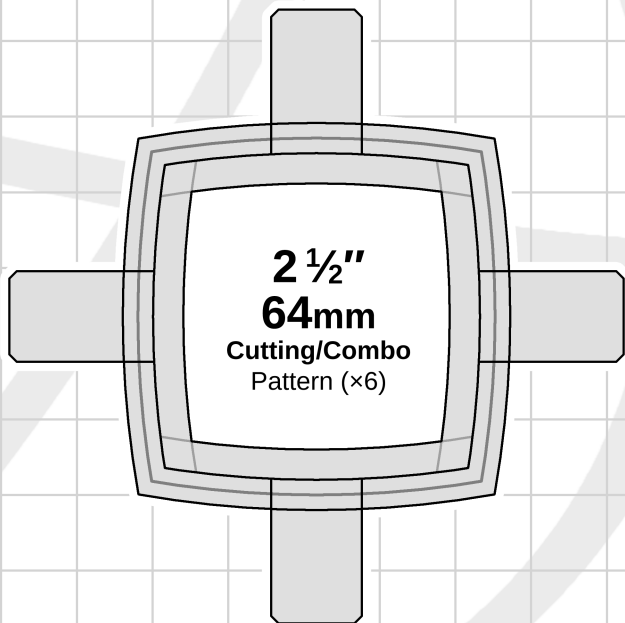
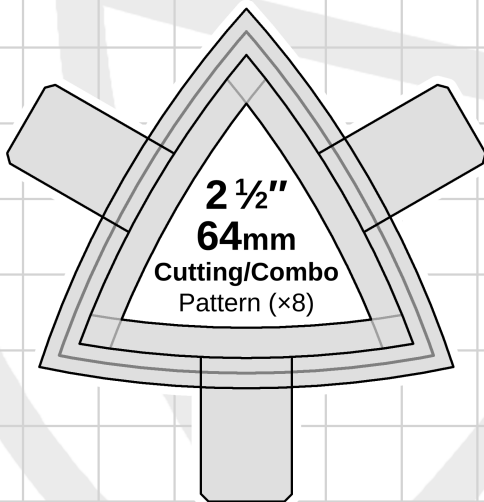
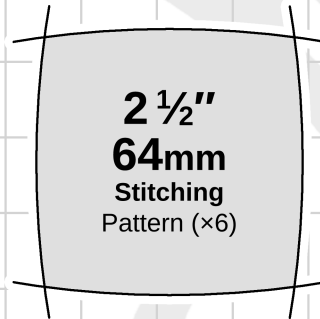
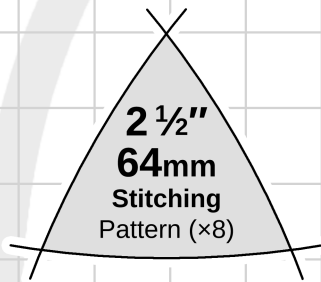



Cuboctahedron (14 panels)

(Pattern sizes are adjusted for corduroy and do not account for gathered seams)

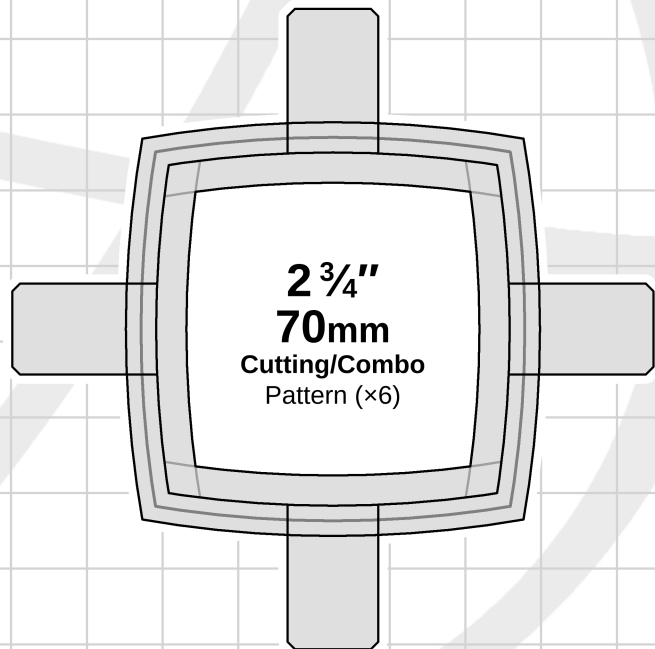
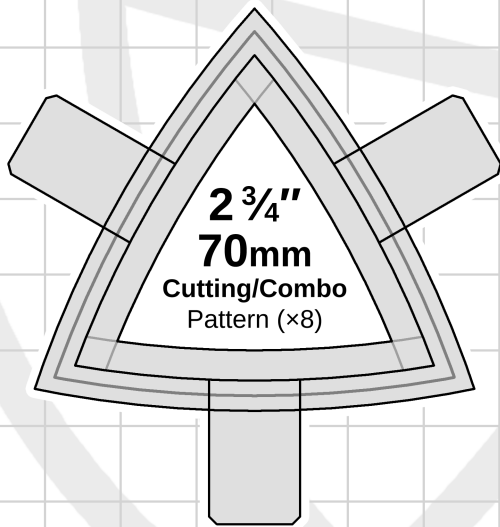
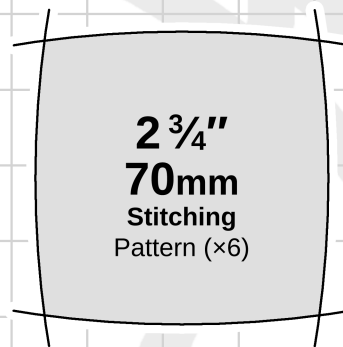
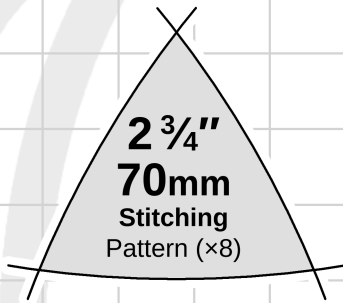



Cuboctahedron (14 panels)

(Pattern sizes are adjusted for corduroy and do not account for gathered seams)

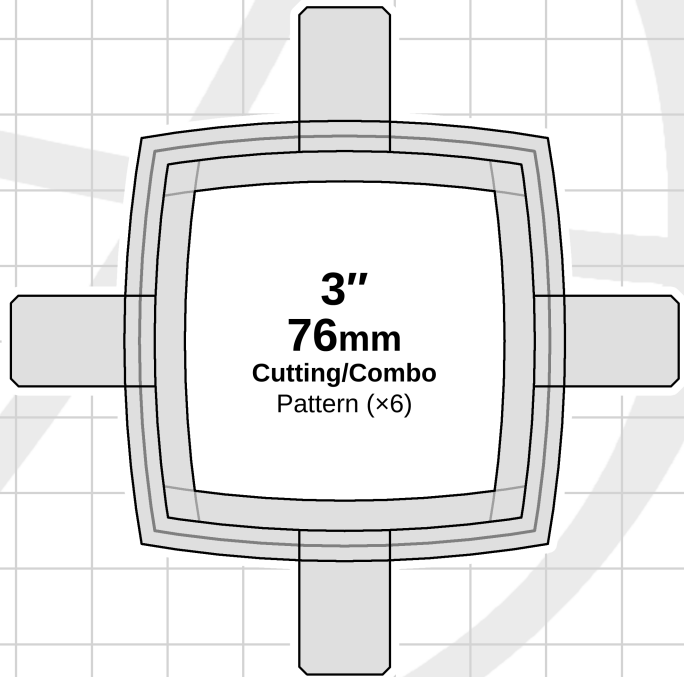
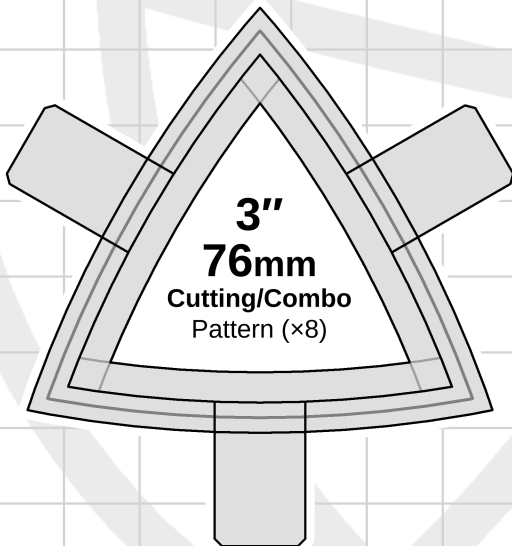
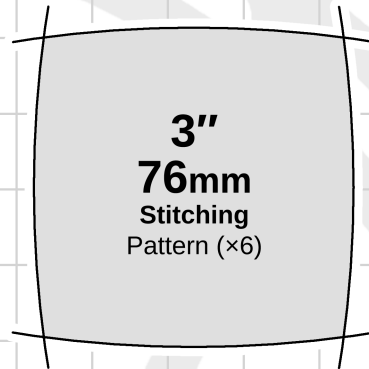
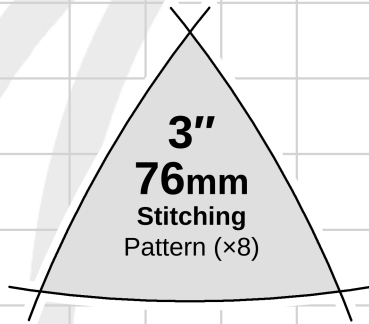



Cuboctahedron (14 panels)

(Pattern sizes are adjusted for corduroy and do not account for gathered seams)



Extra large and versatile patterns for scaling to larger sizes in the Print Dialog (the square is on the next page). Print each pattern twice if you want both a stitching template and a cutting template (or cut out combo templates). The inner patterns (filled with gray) are the stitching patterns. Each dark pattern outside of those marks a 4mm seam allowance interval (at 100% scaling). Use those or the lighter, half-intervals between them to cut out the amount of allowance you want for the cutting templates.

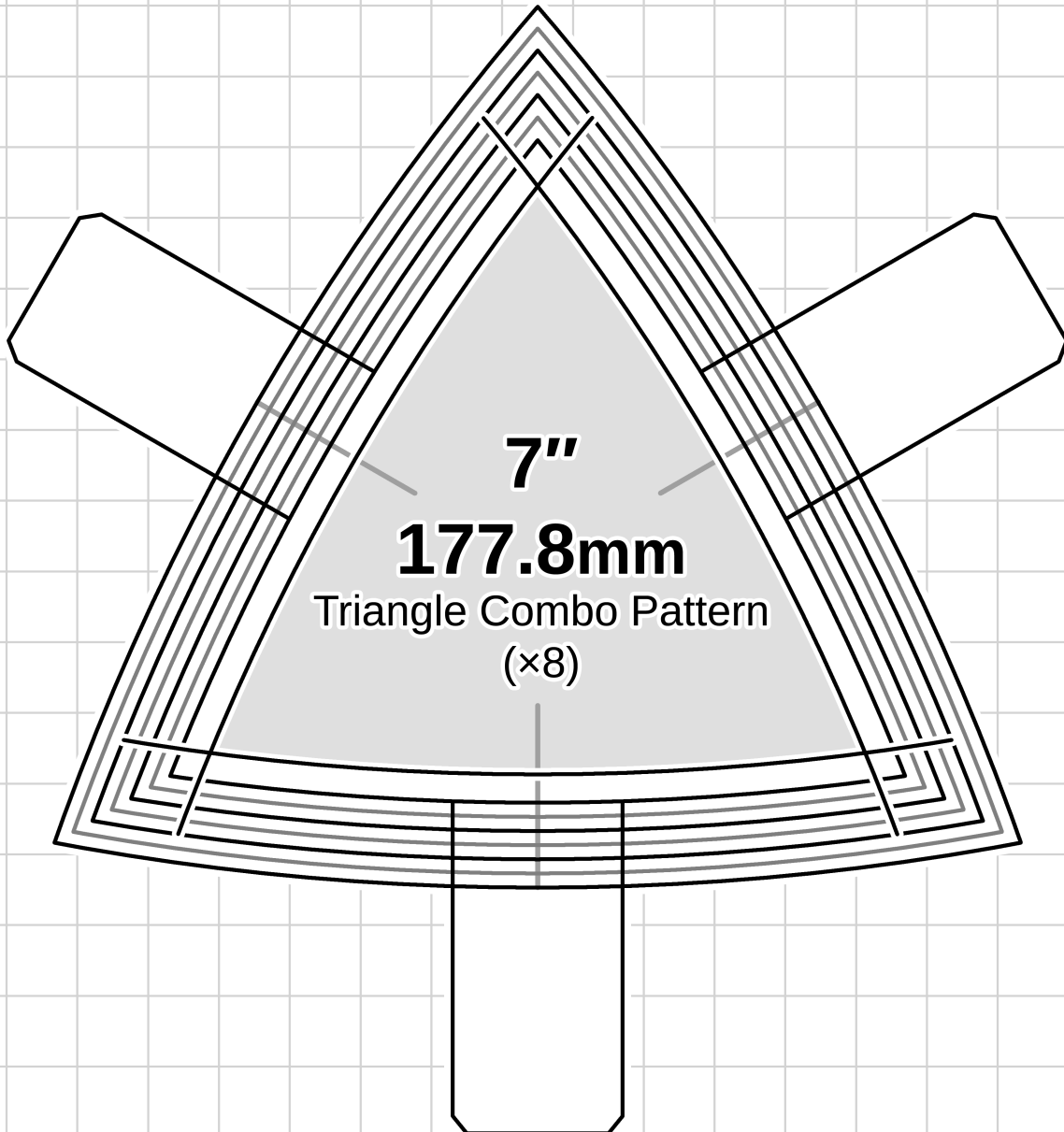



Cuboctahedron (14 panels)

(Pattern sizes are adjusted for corduroy and do not account for gathered seams)

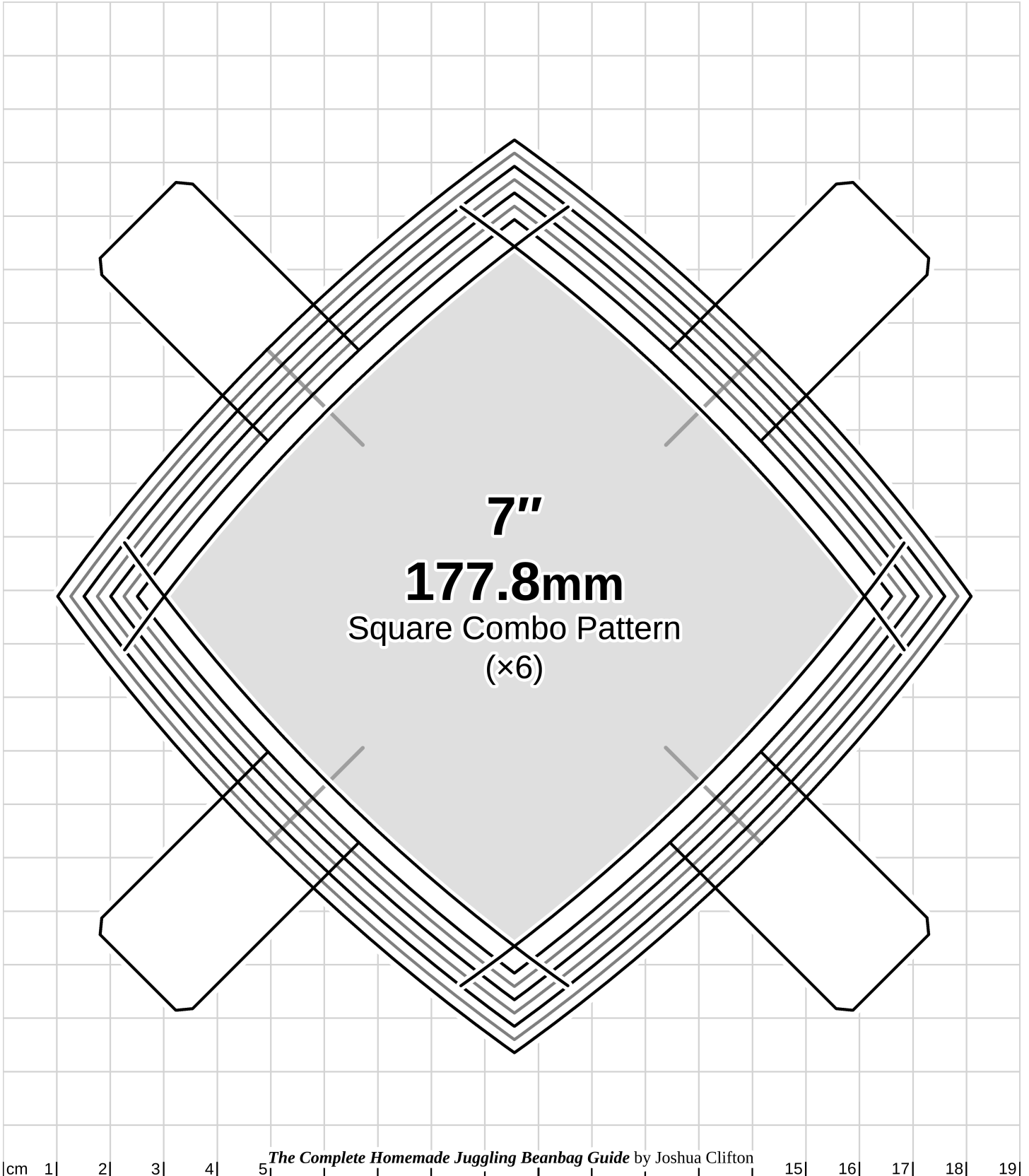



Truncated Octahedron (14 panels)

(Pattern sizes are adjusted for corduroy and do not account for gathered seams)

2" 51mm
Stitching
Pattern (x6)

2" 51mm
Stitching
Pattern (x8)

2" 51mm
Cutting/Combo
Pattern (x8)

2 1/4" 57mm
Stitching
Pattern (x6)

2 1/4" 57mm
Stitching
Pattern (x8)

2 1/4" 57mm
Cutting/Combo
Pattern (x6)

cm 1 2 3 4 5 15 16 17 18 19



Truncated Octahedron (14 panels)

(Pattern sizes are adjusted for corduroy and do not account for gathered seams)

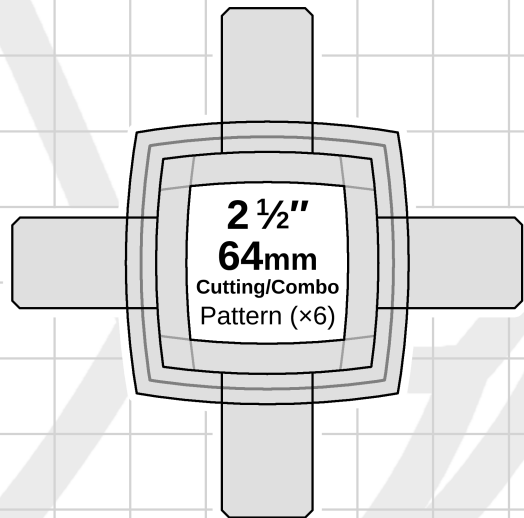
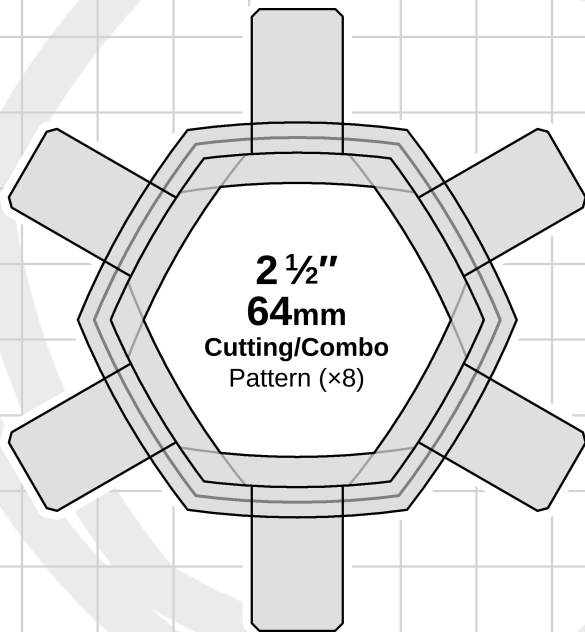
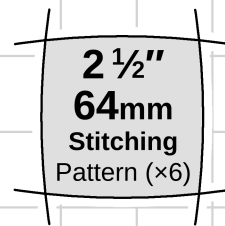
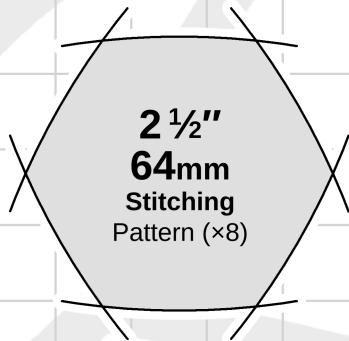



Truncated Octahedron (14 panels)

(Pattern sizes are adjusted for corduroy and do not account for gathered seams)

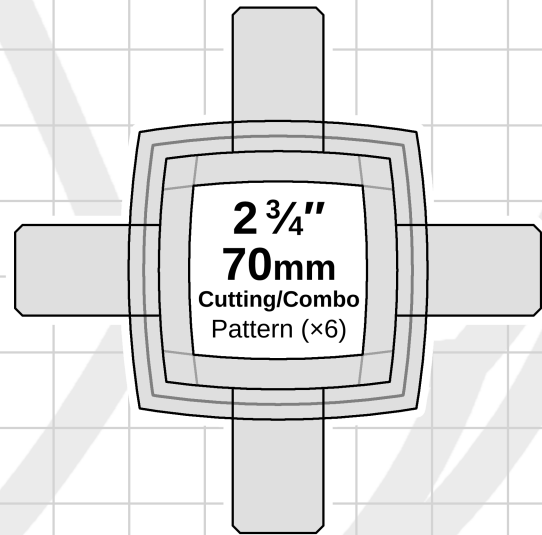
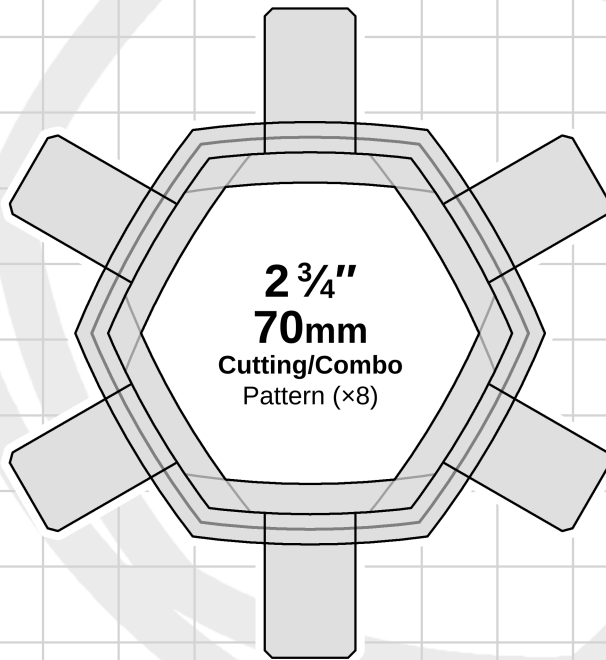
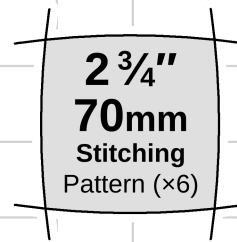
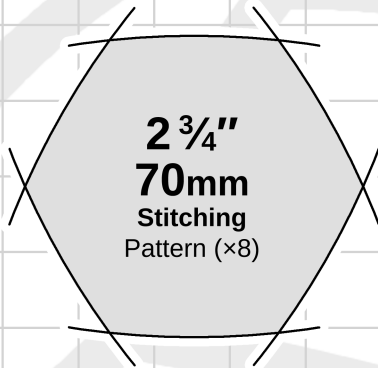



Truncated Octahedron (14 panels)

(Pattern sizes are adjusted for corduroy and do not account for gathered seams)



3"
76mm
Stitching
Pattern (x8)

3"
76mm
Stitching
Pattern (x6)

3"
76mm
Cutting/Combo
Pattern (x8)

3"
76mm
Cutting/Combo
Pattern (x6)

cm 1 2 3 4 5 *The Complete Homemade Juggling Beanbag Guide* by Joshua Clifton 15 16 17 18 19



Truncated Octahedron (14 panels)

(Pattern sizes are adjusted for corduroy and do not account for gathered seams)



Extra large and versatile patterns for scaling to larger sizes in the Print Dialog (the square is on the next page). Print each pattern twice if you want both a stitching template and a cutting template (or cut out combo templates). The inner patterns (filled with gray) are the stitching patterns. Each dark pattern outside of those marks a 4mm seam allowance interval (at 100% scaling). Use those or the lighter, half-intervals between them to cut out the amount of allowance you want for the cutting templates.

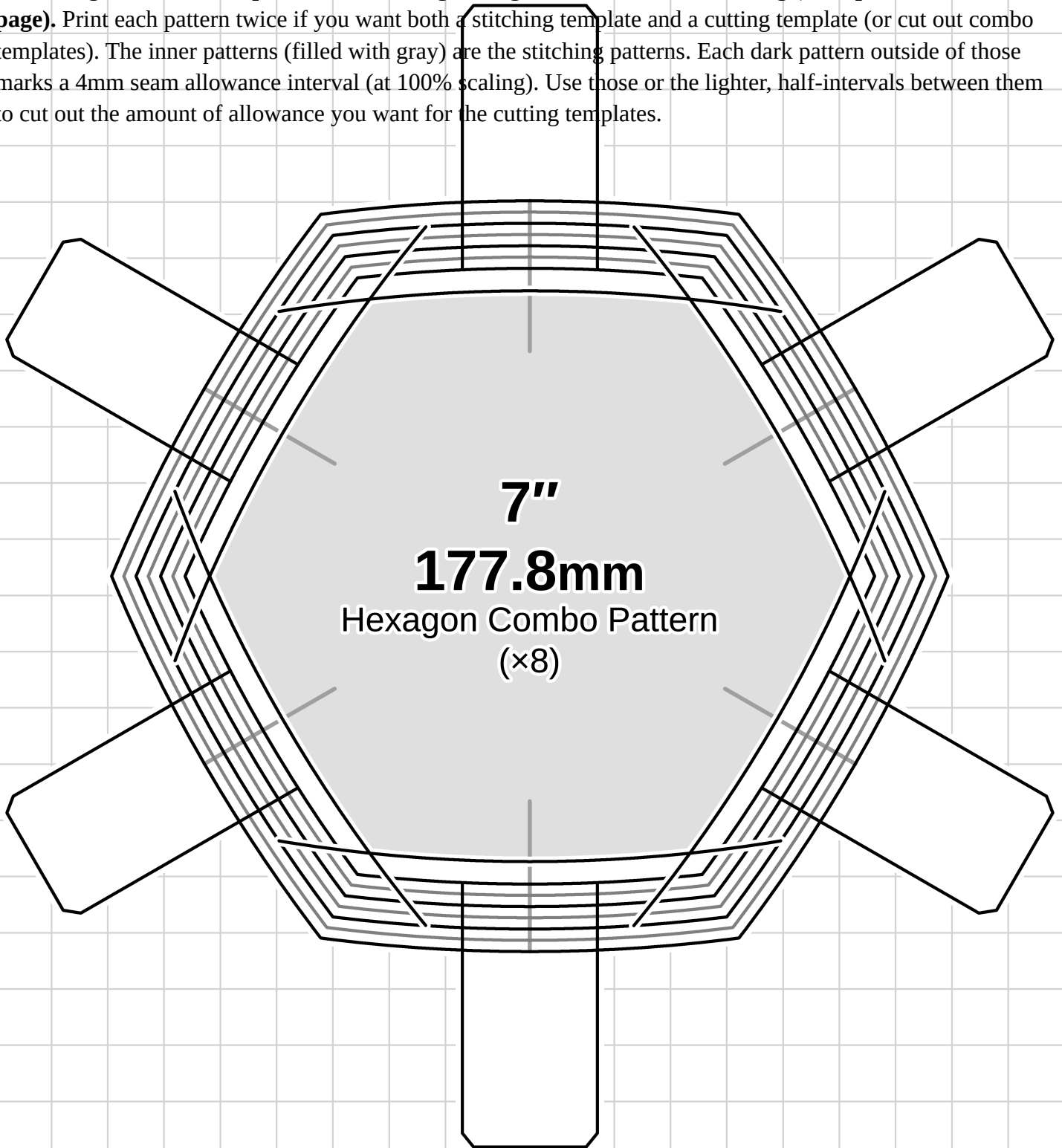



Truncated Octahedron (14 panels)

(Pattern sizes are adjusted for corduroy and do not account for gathered seams)

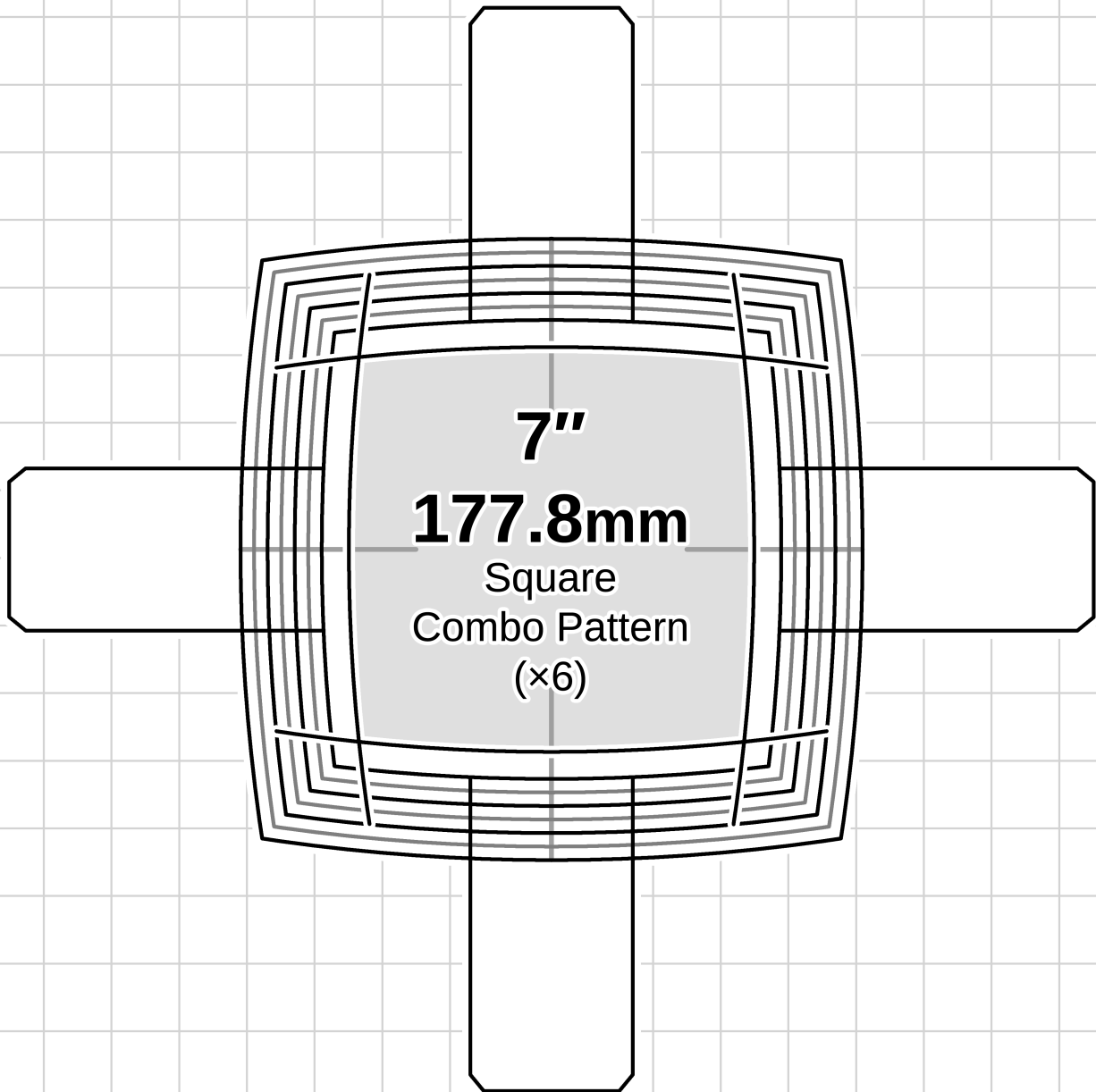

14-PANEL SPHERICAL EQUIDISTANT CUBOCTAHEDRON

[Back to Pattern Index](#)

On the following pages are patterns for beanbag diameters from 2" – 3" in $\frac{1}{4}$ " increments, and 7" patterns for scaling to larger sizes. The patterns are reduced by 5.81% from the mathematical calculation to account for the inflation in size I observed in my corduroy bag. **If you use a dense/stiff or completely non-stretch fabric, I recommend enlarging the pattern to about 103%.**

To make the templates, I recommend cutting out the portions of the paper with the patterns you want and gluing or taping them to your template material, and then cutting along the patterns.

The cutting patterns have 4mm, 6mm, and 8mm allowances so you can choose the amount that works best for your fabric and preference (the lighter, 6mm pattern is a hair under $\frac{1}{4}$ "), and they include **tabs for the optional combo type template** (stitching pattern on the inside, cutting pattern on the outside, with the tabs to help you hold it down). The hex's small tabs may not be needed.

The examples on the right show the **three ways you can cut out the Cutting/Combo templates** (using the 8mm allowance). Remember that the cutting patterns have slightly different proportions from the stitching patterns (they are parallel, not proportional), so you should not use them as stitching patterns.

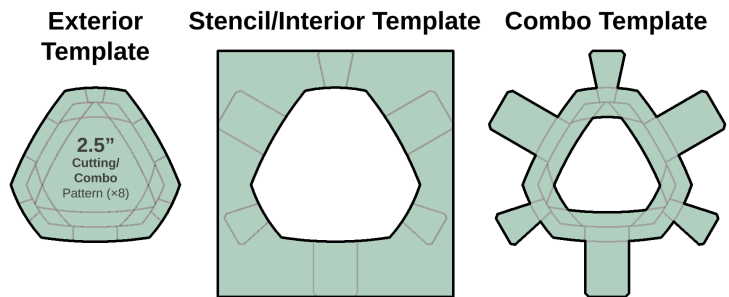

If you cut out these patterns as straight-edged shapes (from corner to corner), the resulting beanbag will be about 98% the size of the circular-edged version. So to produce the same size, scale the printout to 102%.



Equidistant Cuboctahedron (14 Panels)

(Pattern sizes are adjusted for corduroy and do not account for gathered seams)

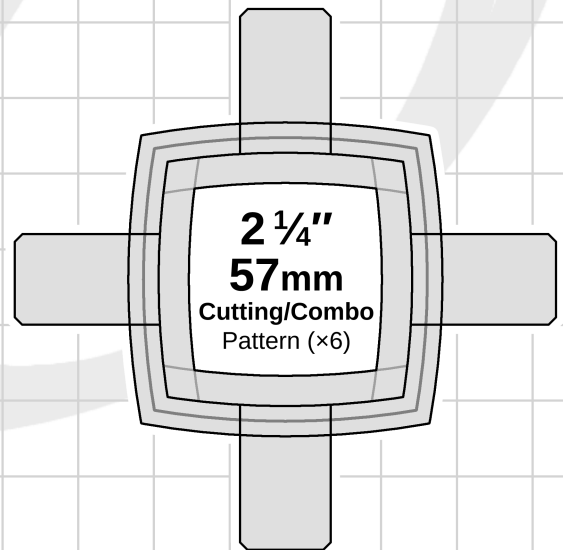
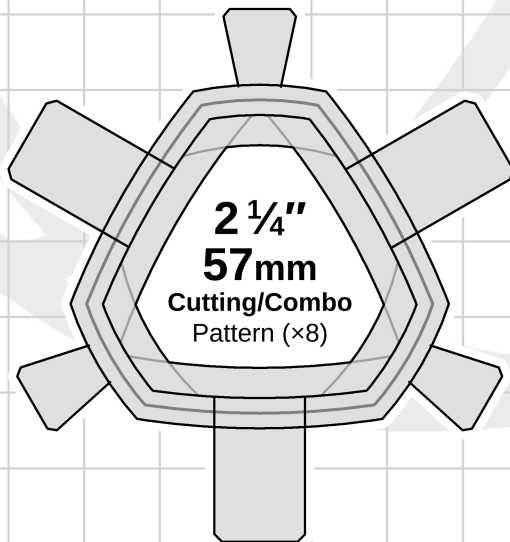
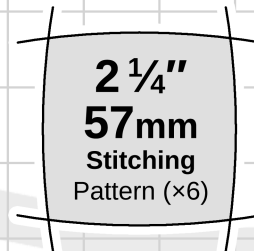
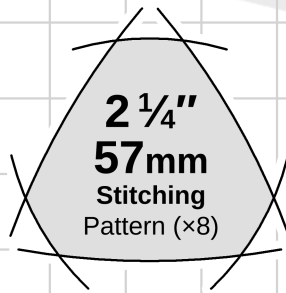
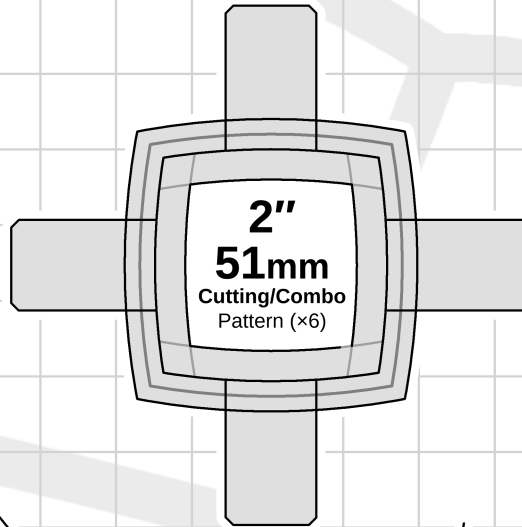
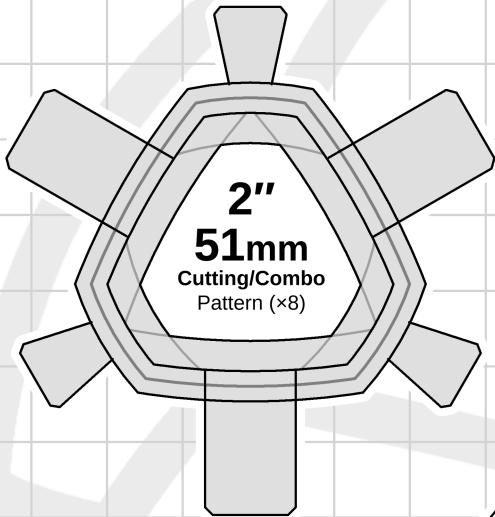
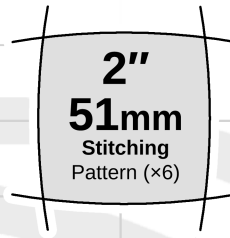
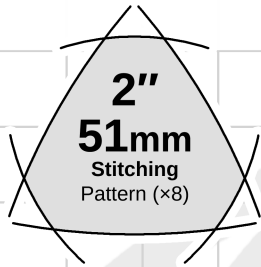



Equidistant Cuboctahedron (14 Panels)

(Pattern sizes are adjusted for corduroy and do not account for gathered seams)

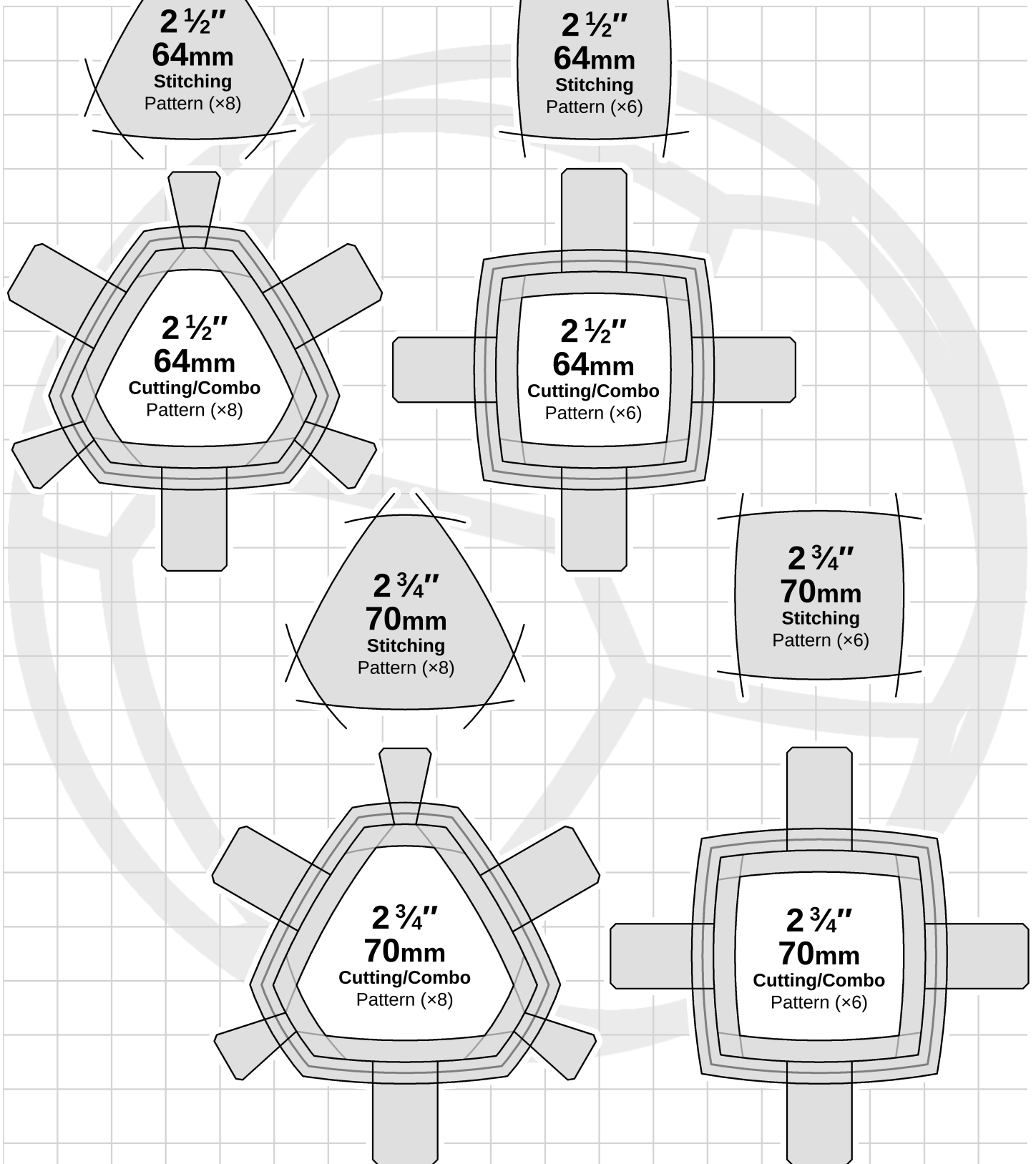

cm 1 | 2 | 3 | 4 | 5 | *The Complete Homemade Juggling Beanbag Guide* by Joshua Clifton | 15 | 16 | 17 | 18 | 19



Equidistant Cuboctahedron (14 Panels)

(Pattern sizes are adjusted for corduroy and do not account for gathered seams)

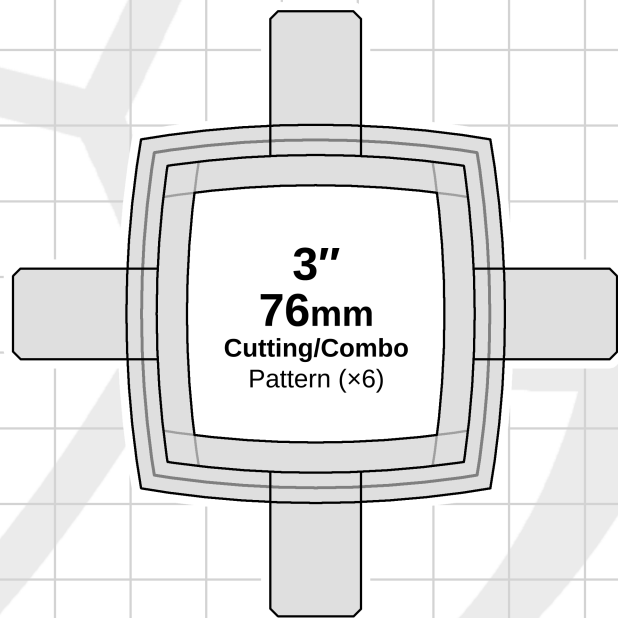
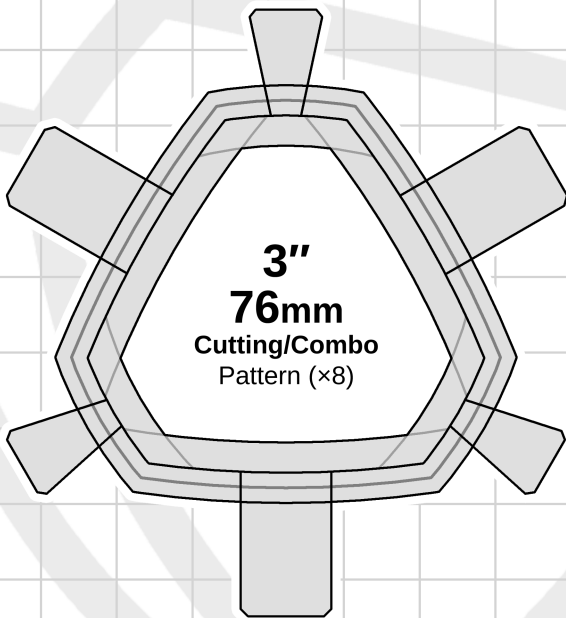
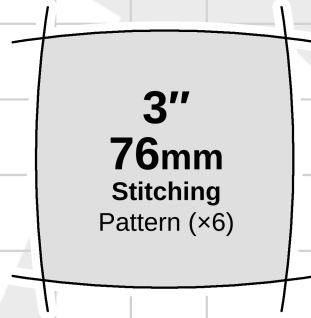
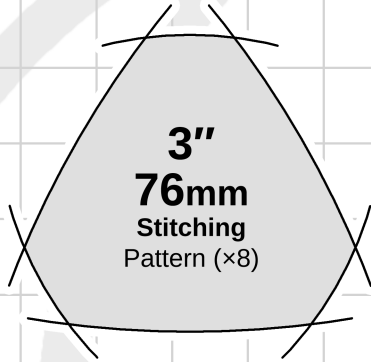



Equidistant Cuboctahedron (14 Panels)

(Pattern sizes are adjusted for corduroy and do not account for gathered seams)



Extra large and versatile patterns for scaling to larger sizes in the Print Dialog (the square is on the next page). Print each pattern twice if you want both a stitching template and a cutting template (or cut out combo templates). The inner patterns (filled with gray) are the stitching patterns. Each dark pattern outside of those marks a 4mm seam allowance interval (at 100% scaling). Use those or the lighter, half-intervals between them to cut out the amount of allowance you want for the cutting templates.

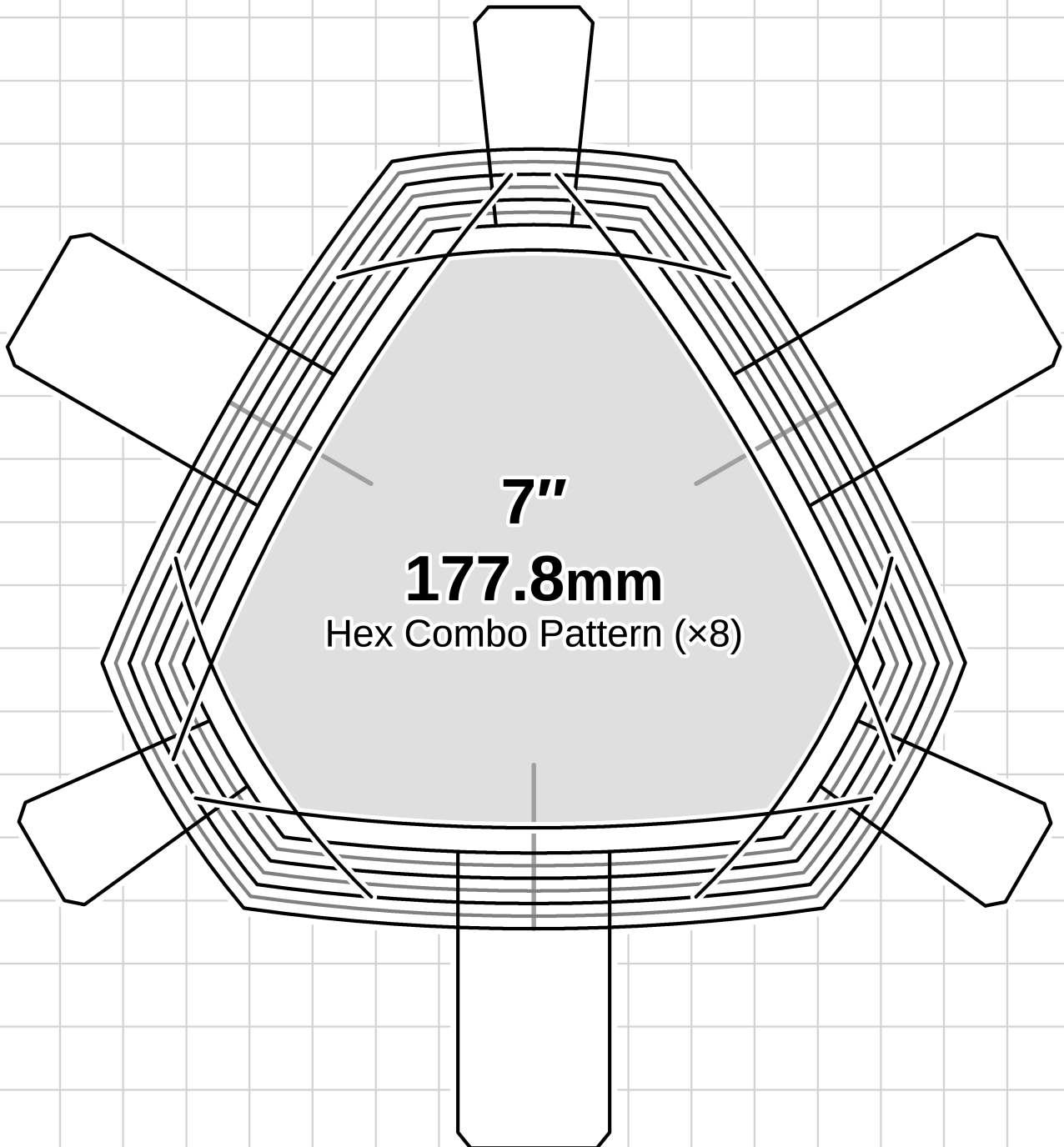



Equidistant Cuboctahedron (14 Panels)

(Pattern sizes are adjusted for corduroy and do not account for gathered seams)

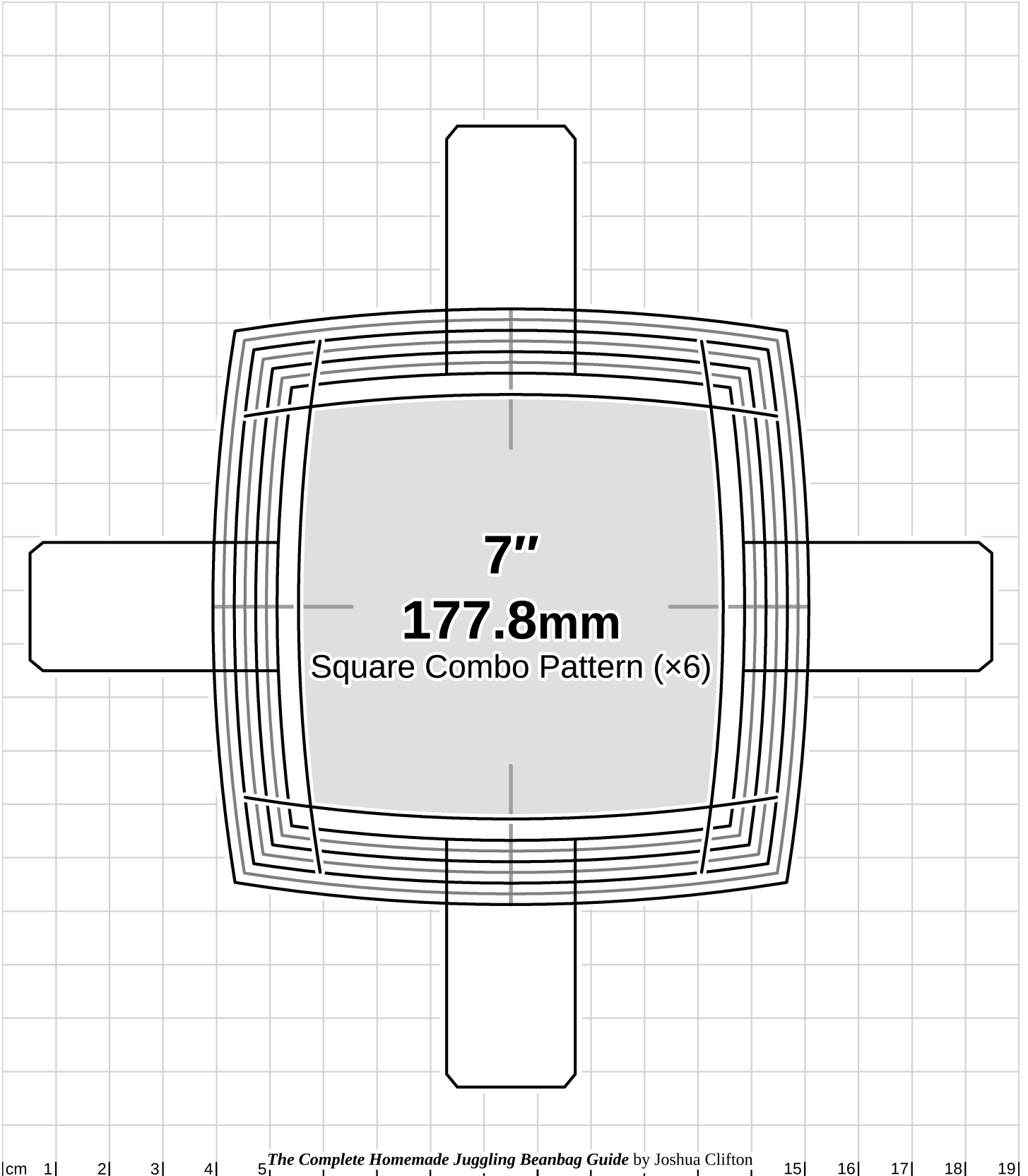

24-PANEL ISOVERTEX DELTOIDAL ICOSITETRAHEDRON

[Back to Pattern Index](#)



On the following pages are patterns for beanbag diameters from 2" – 3" in $\frac{1}{4}$ " increments, and a 7" pattern for scaling to larger sizes. The patterns are reduced by 1.93% from the mathematical calculation to account for the inflation in size I observed in my corduroy bag. **If you use a dense/stiff or completely non-stretch fabric, I recommend enlarging the pattern to about 102% to get the intended ball size.**

To make the templates, I recommend cutting out the portions of the paper with the patterns you want and gluing or taping them to your template material, and then cutting along the patterns.

The cutting patterns have 4mm, 6mm, and 8mm allowances so you can choose the amount that works best for your fabric and preference, and they include **tabs for the optional combo type template** (stitching pattern on the inside, cutting pattern on the outside, with the tabs to help you hold it down).

The examples on the right show the **three ways you can cut out the Cutting/Combo templates**. Remember that the cutting patterns have slightly different proportions from the stitching patterns (they are parallel, not proportional), so you should not use them as stitching patterns.

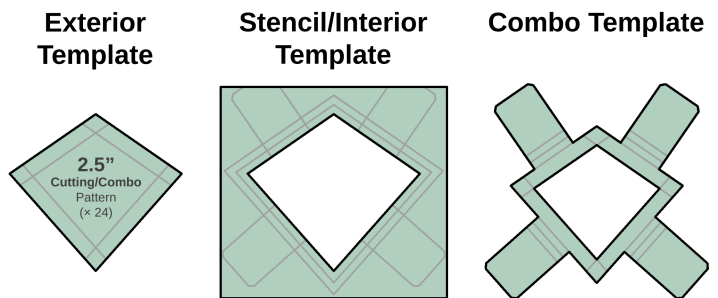



Deltoidal Icositetrahedron (24 Panels)

Isovertex kite (forms the best cloth sphere)

Kite angles: 110.769°, 83.077°



(Pattern sizes are adjusted for corduroy and do not account for gathered seams)

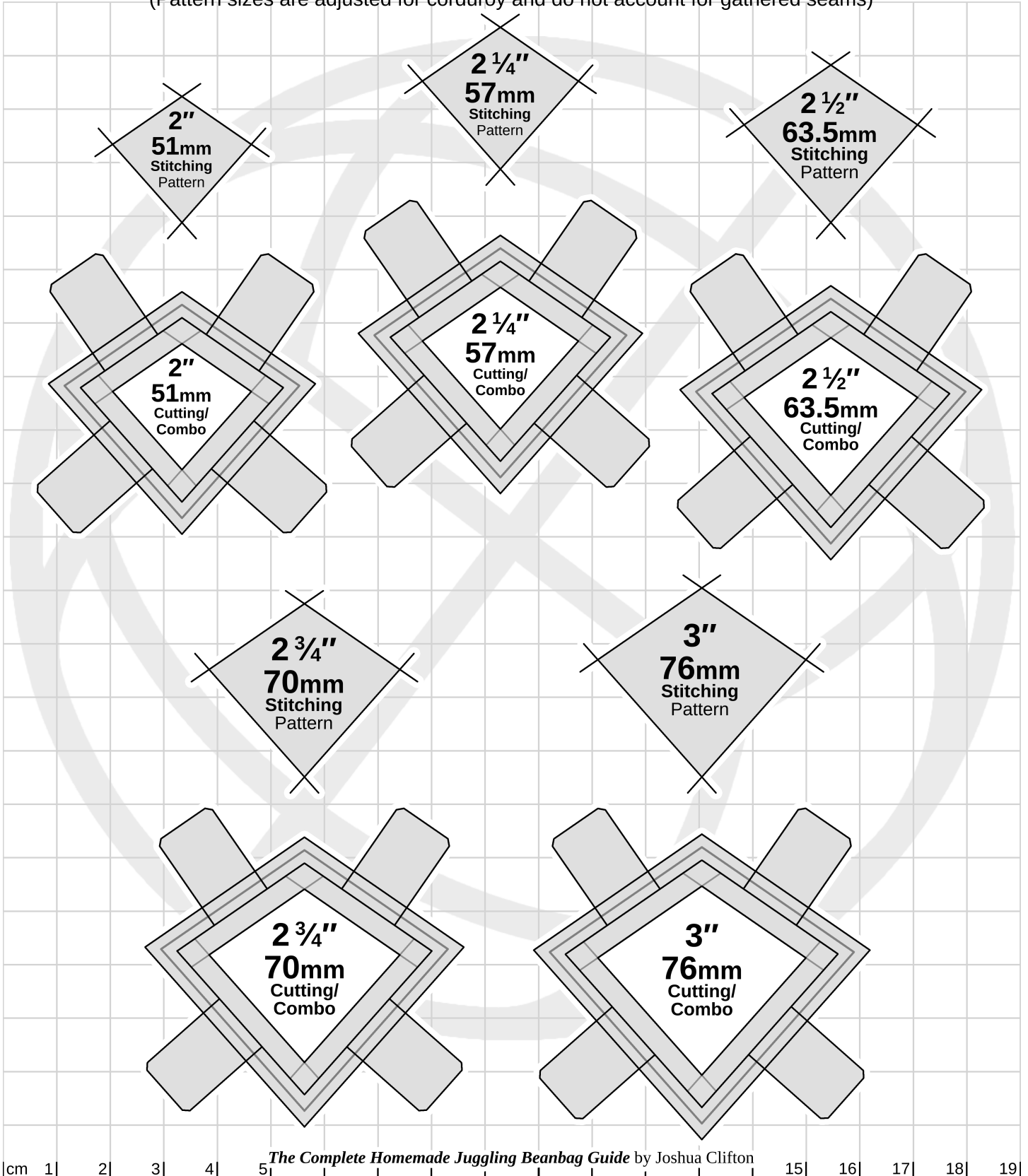



Deltoidal Icositetrahedron (24 Panels)

Isovertex kite (forms the best cloth sphere)

Kite angles: 110.769°, 83.077°

(Pattern sizes are adjusted for corduroy and do not account for gathered seams)



Extra large and versatile pattern for scaling to larger sizes in the Print Dialog. Print twice if you want both a stitching template and a cutting template (or cut out a combo template). The inner pattern (filled with gray) is the stitching pattern. Each dark pattern outside of that marks a 4mm seam allowance interval (at 100% scaling). Use those or the lighter, half-intervals between them to cut out the amount of allowance you want for the cutting template.

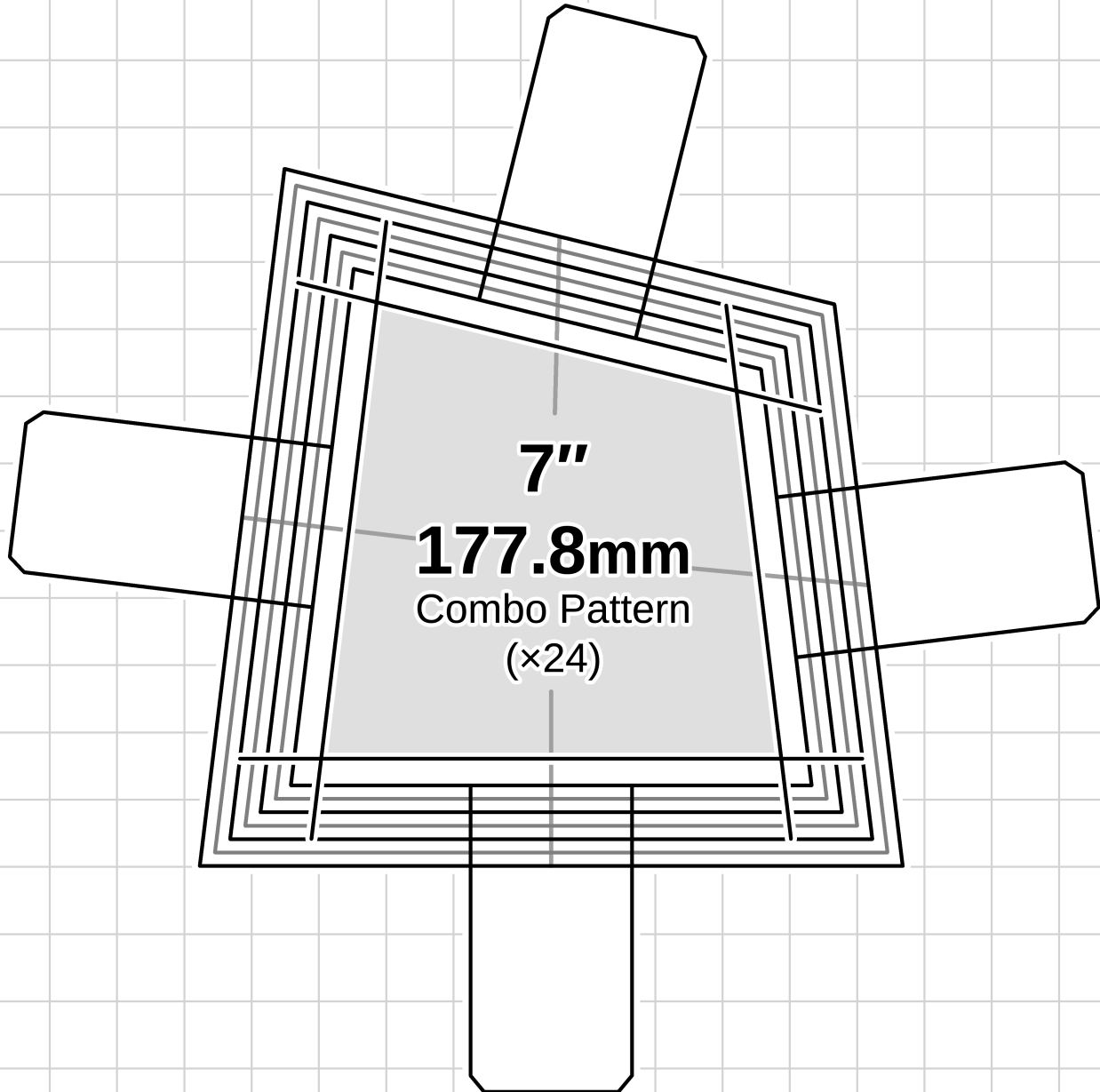

26-PANEL RHOMBICUBOCTAHEDRON

[Back to Pattern Index](#)

On the following pages are patterns for beanbag diameters from 2" – 3" in $\frac{1}{4}$ " increments, and 7" patterns for scaling to larger sizes. The patterns are reduced by 3.75% from the mathematical calculation to account for the inflation in size I observed in my corduroy bag. **If you use a dense/stiff or completely non-stretch fabric, I recommend enlarging the pattern to about 104% to get the intended ball size.**

To make the templates, I recommend cutting out the portions of the paper with the patterns you want and gluing or taping them to your template material, and then cutting along the patterns.

The patterns are Combo patterns. They have the **stitching patterns on the inside (filled with gray)** and the **cutting patterns on the outside**, with **4mm, 6mm, and 8mm allowances** so you can choose the amount that works best for your fabric and preference (the lighter, 6mm pattern is a hair under $\frac{1}{4}$ "). They also include **tabs to help you hold the templates down.**

The examples on the right show the **three ways you can cut out the templates.** If you want separate stitching and cutting templates, you will need to print the patterns twice.

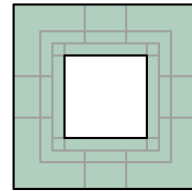
Exterior
TemplateStencil/Interior
Template

Combo Template

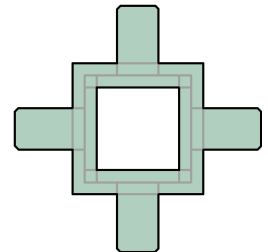



Rhombicuboctahedron (26 Panels)

Uses 8 triangles, 18 squares

Pattern sizes are adjusted for corduroy and do not account for gathered seams.
For footbags with gathered seams, try two sizes (1/2") or 25% larger than target diameter.



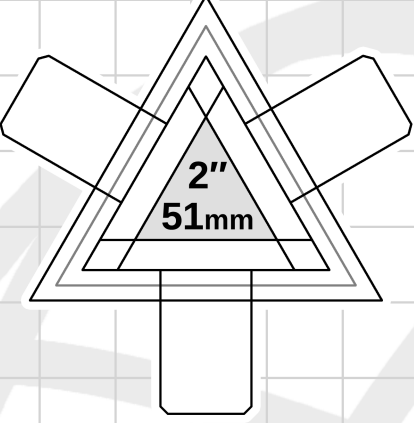

2"
51mm

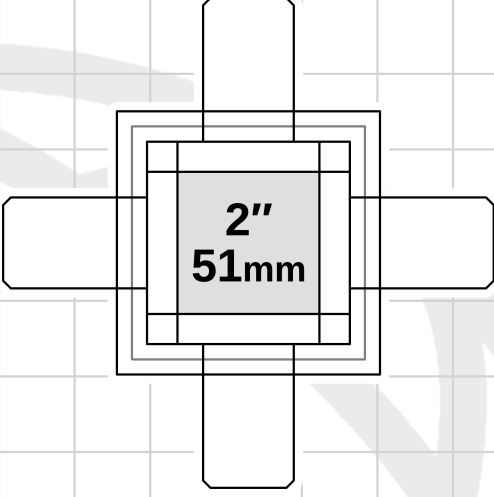

2"
51mm

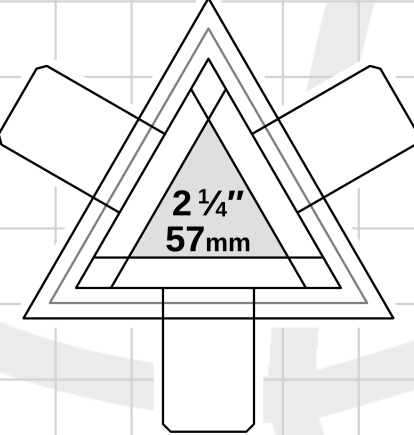

2 1/4"
57mm

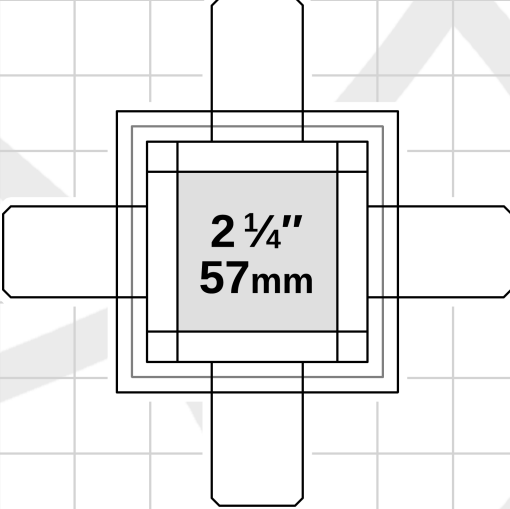

2 1/4"
57mm

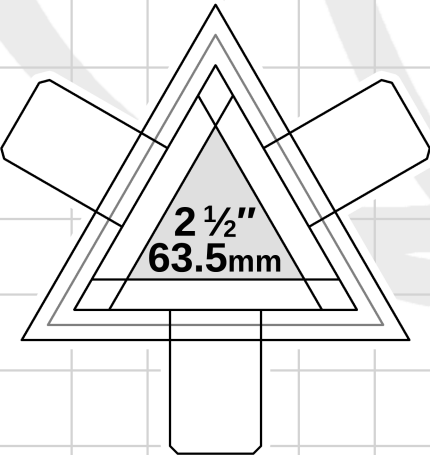

2 1/2"
63.5mm

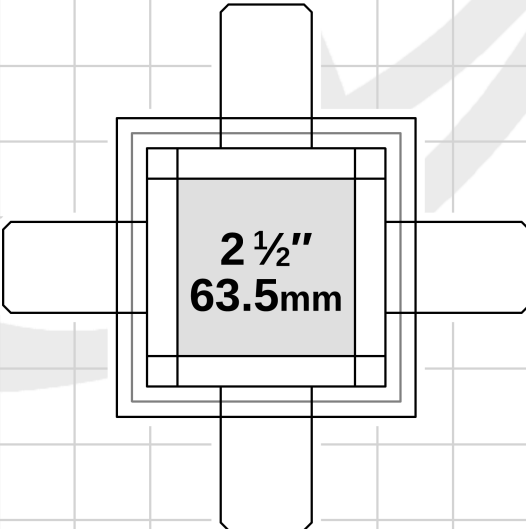

2 1/2"
63.5mm



Rhombicuboctahedron (26 Panels)

Uses 8 triangles, 18 squares

Pattern sizes are adjusted for corduroy and do not account for gathered seams.
For footbags with gathered seams, try two sizes (1/2") or 25% larger than target diameter.

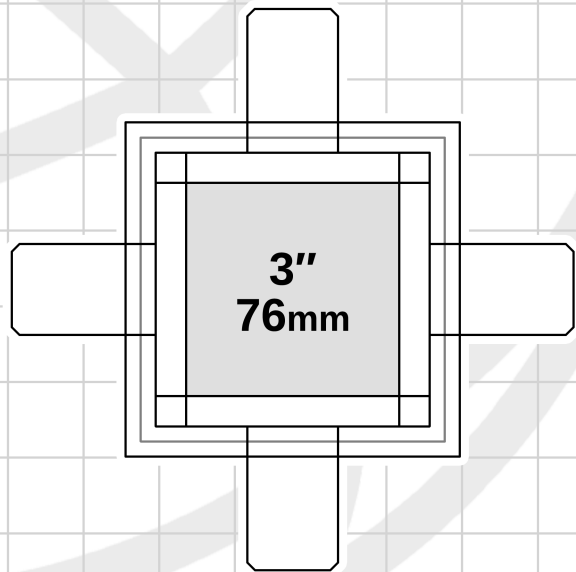
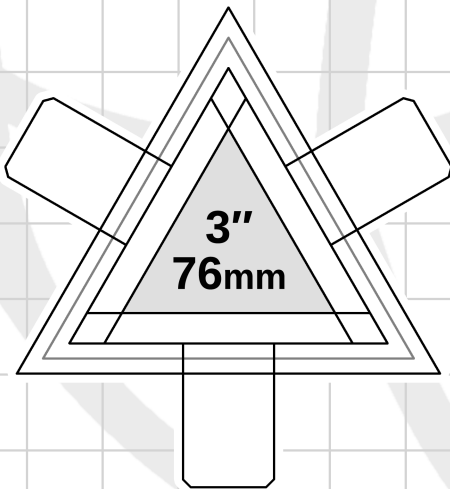
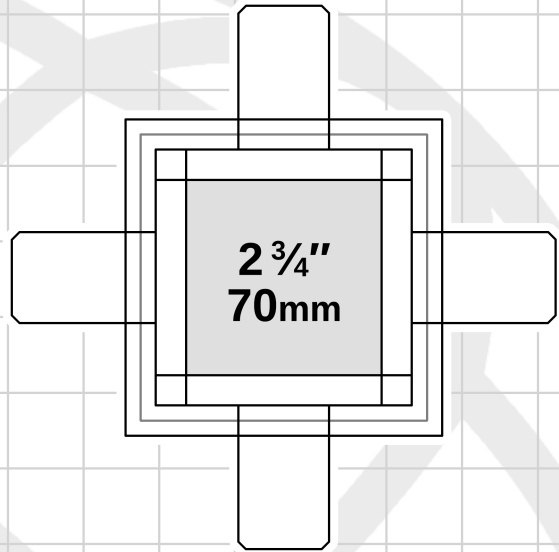
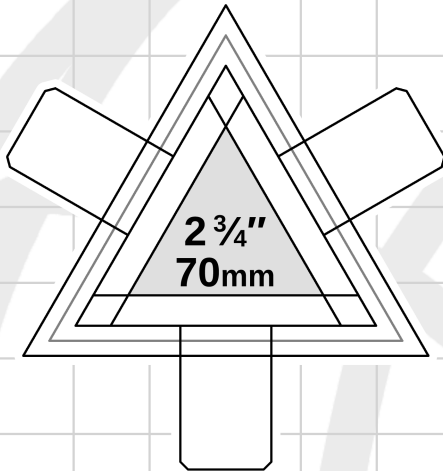



Rhombicuboctahedron (26 Panels)

Uses 8 triangles, 18 squares

Pattern sizes are adjusted for corduroy and do not account for gathered seams.
For footbags with gathered seams, try two sizes (1/2") or 25% larger than target diameter.



Extra large and versatile patterns for scaling to larger sizes in the Print Dialog (the square is on the next page). Print each pattern twice if you want both a stitching template and a cutting template (or cut out combo templates). The inner patterns (filled with gray) are the stitching patterns. Each dark pattern outside of those marks a 4mm seam allowance interval (at 100% scaling). Use those or the lighter, half-intervals between them to cut out the amount of allowance you want for the cutting templates.

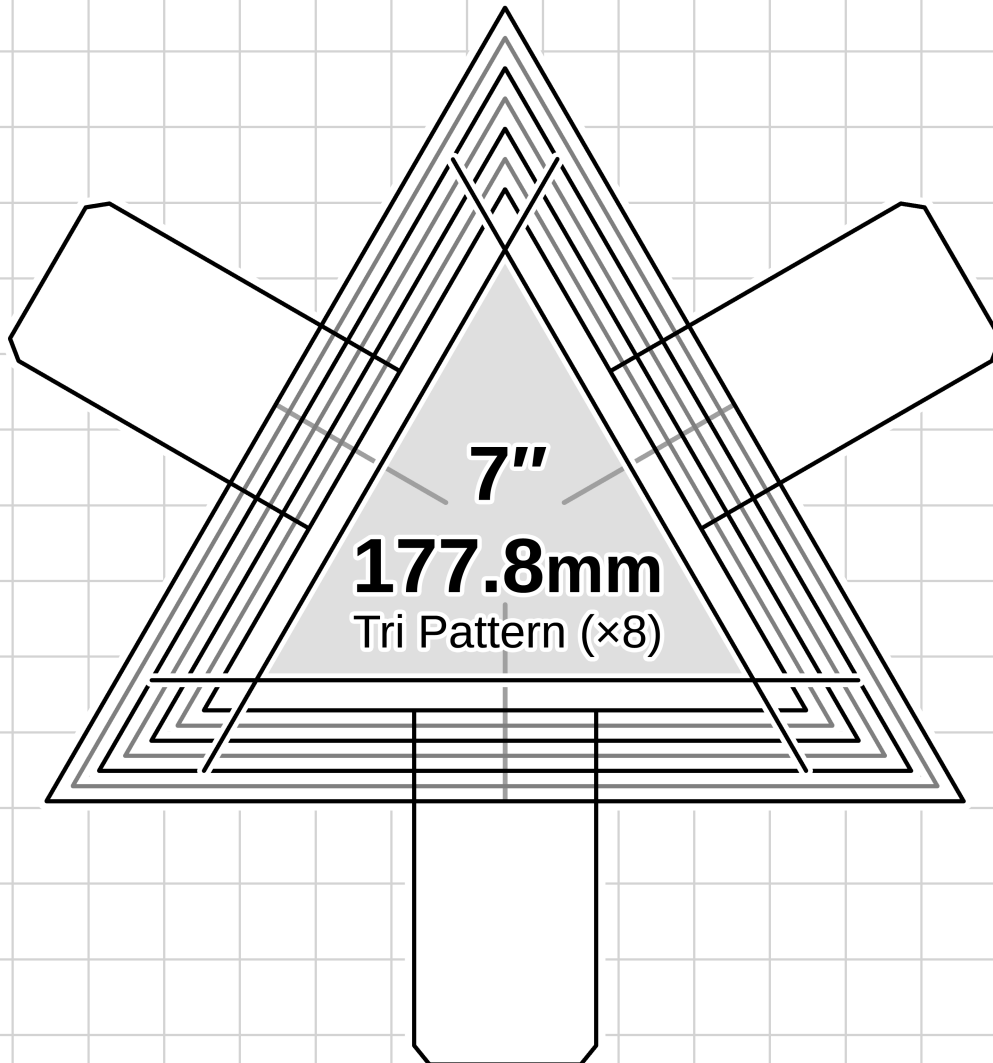



Rhombicuboctahedron (26 Panels)

Uses 8 triangles, 18 squares

Pattern sizes are adjusted for corduroy and do not account for gathered seams.
For footbags with gathered seams, try two sizes (1/2") or 25% larger than target diameter.

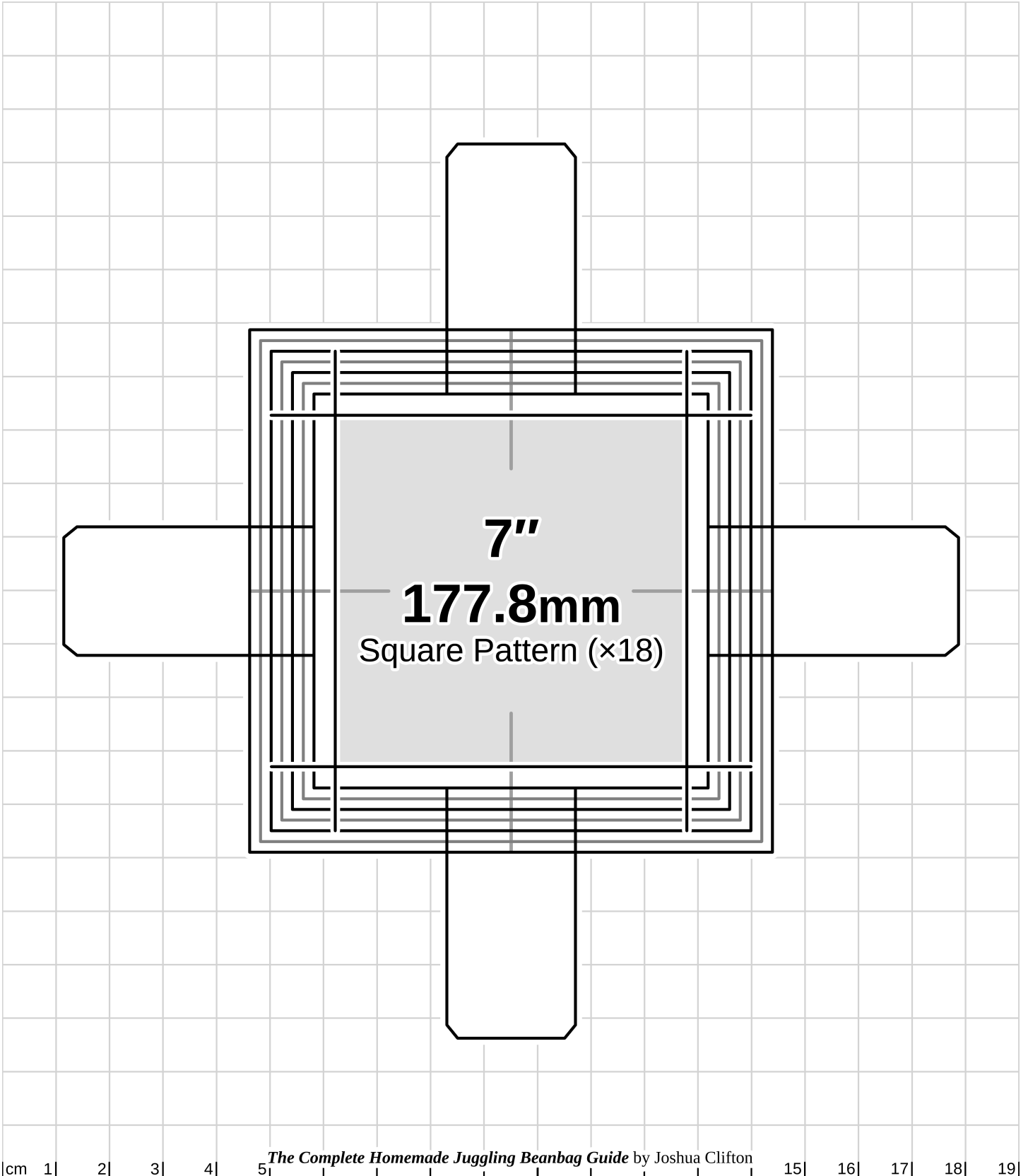

30-PANEL ISOVERTEX RHOMBIC TRIACONTAHEDRON

[Back to Pattern Index](#)



On the following pages are patterns for beanbag diameters from 2" – 3" in $\frac{1}{4}$ " increments, and a 7" pattern for scaling to larger sizes. The patterns are reduced by 2.71% from the mathematical calculation to account for the inflation in size I observed in my corduroy bag. **If you use a dense/stiff or completely non-stretch fabric, I recommend enlarging the pattern to about 103% to get the intended ball size.**

To make the template, I recommend cutting out the portion of the paper with the pattern you want and gluing or taping it to your template material, and then cutting along the pattern.

The patterns are Combo patterns. They have the **stitching patterns on the inside (filled with gray)** and the **cutting patterns on the outside, with 4mm, 6mm, and 8mm allowances** so you can choose the amount that works best for your fabric and preference (the lighter, 6mm pattern is a hair under $\frac{1}{4}$ "). They also include **tabs to help you hold the templates down.**

The examples on the right show the **three ways you can cut out the templates.** If you want separate stitching and cutting templates, you will need to print the patterns twice.

Exterior
Template



Stencil/Interior
Template

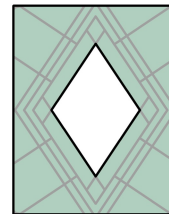

Combo Template

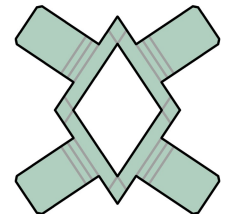

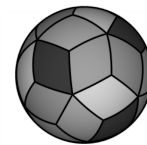

Rhombic Triacanthedron (30 panels)

Isovertex rhombus (produces a better cloth sphere)

Pattern sizes are adjusted for corduroy and do not account for gathered seams.
 For footbags with gathered seams, try two sizes ($\frac{1}{2}$ " or 25% larger than target diameter.

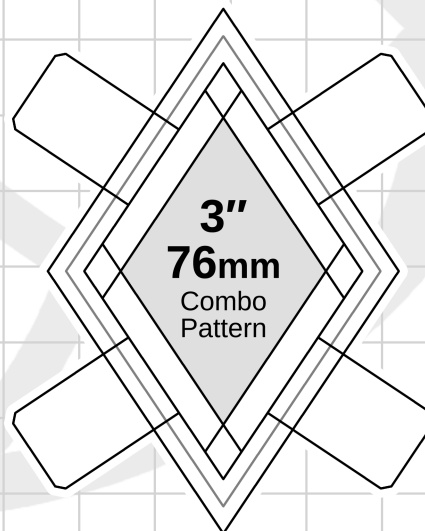
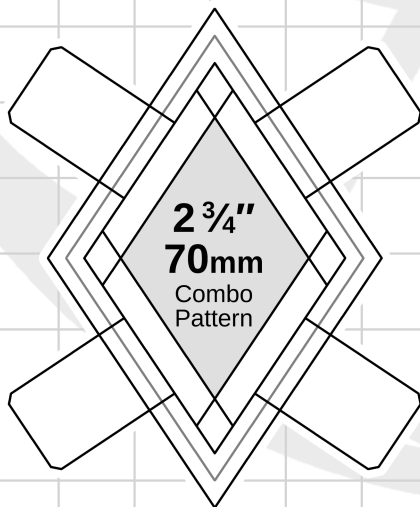
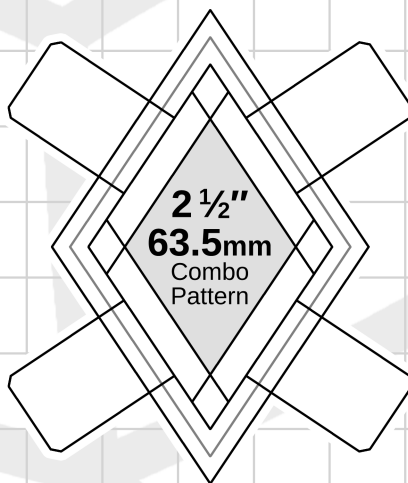
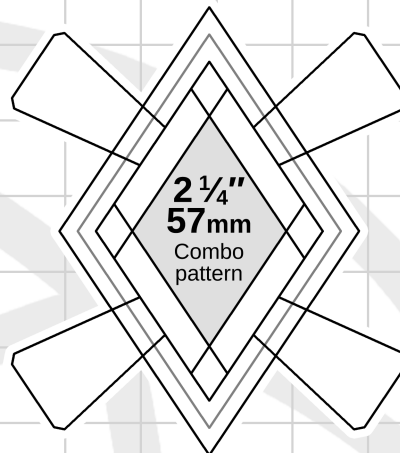
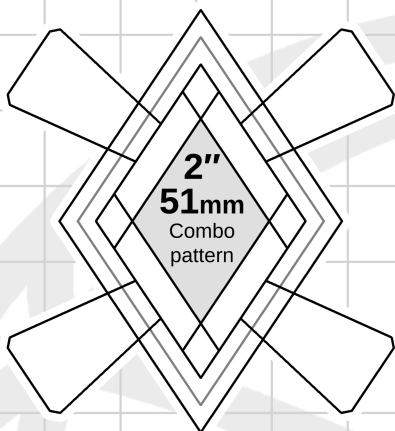



Rhombic Triacanthedron (30 panels)

Isovertex rhombus (produces a better cloth sphere)

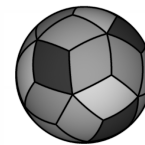

Pattern sizes are adjusted for corduroy and do not account for gathered seams.

For footbags with gathered seams, try two sizes ($\frac{1}{2}$ " or 25% larger than target diameter.

Extra large and versatile pattern for scaling to larger sizes in the Print Dialog. Print twice if you want both a stitching template and a cutting template (or cut out a combo template). The inner pattern (filled with gray) is the stitching pattern. Each dark pattern outside of that marks a 4mm seam allowance interval (at 100% scaling). Use those or the lighter, half-intervals between them to cut out the amount of allowance you want for the cutting template.

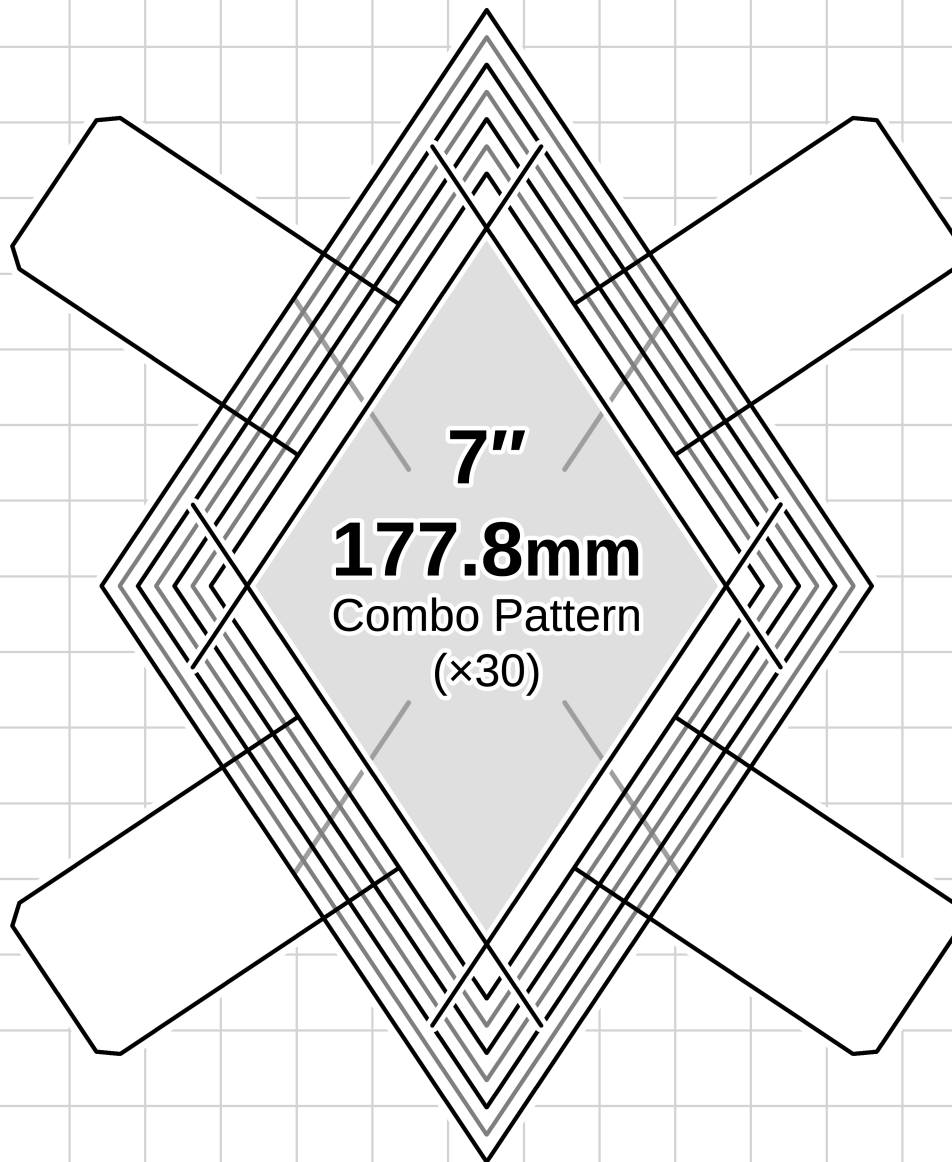

32-PANEL EQUIDISTANT TRUNCATED ICOSAHEDRON AND VARIATIONS

[Back to Pattern Index](#)

The **main, Equidistant design**

patterns begin on the next page.

Those are followed

by the •[Footbag Hex Variation](#), the

•[Triangle Variation](#)

(icosidodecahedron), and finally the

•[Equilateral Hex Variation](#) (truncated icosahedron/soccer ball).

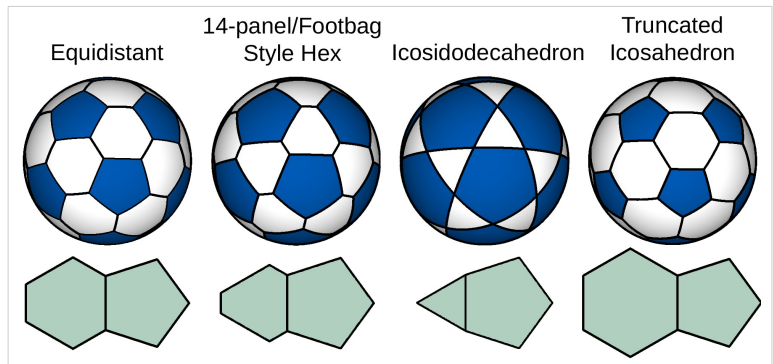

The patterns are for beanbag diameters from 2" – 3" in $\frac{1}{4}$ " increments, and there are 7" patterns for scaling to larger sizes. The Hex variant patterns are reduced by 3.8% and the Triangle variant by 3.0% from the mathematical calculations to account for the inflation in size I observed in my corduroy bag. **If you use a dense/stiff or completely non-stretch fabric, I recommend enlarging the pattern to about 105%.**

To make the templates, I recommend cutting out the portions of the paper with the patterns you want and gluing or taping them to your template material, and then cutting along the patterns.

The patterns are Combo patterns. They have the **stitching patterns on the inside (filled with gray)** and the **cutting patterns on the outside**, with **4mm, 6mm, and 8mm allowances** so you can choose the amount that works best for your fabric and preference (the lighter, 6mm pattern is a hair under $\frac{1}{4}$ "). They also include **tabs to help you hold the templates down**. You may not need all the tabs with a rigid enough template material.

The examples on the right show the **three ways you can cut out the templates**. If you want separate stitching and cutting templates, you will need to print the patterns twice.

Exterior Template



Stencil/Interior Template

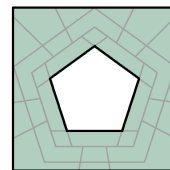

Combo Template

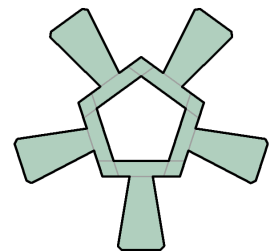



Equidistant Truncated Icosahedron (32 Panels)

Uses 20 hexagons, 12 pentagons

Pattern sizes are adjusted for corduroy and do not account for gathered seams.
For footbags with gathered seams, try two sizes ($\frac{1}{2}$ ") or 25% larger than target diameter.



Row	Column	Size (Inches)	Size (mm)	Quantity
1	1	2"	51mm	($\times 20$)
1	2	2"	51mm	($\times 12$)
2	1	2 $\frac{1}{4}$ "	57mm	($\times 20$)
2	2	2 $\frac{1}{4}$ "	57mm	($\times 12$)
3	1	2 $\frac{1}{2}$ "	63.5mm	($\times 20$)
3	2	2 $\frac{1}{2}$ "	63.5mm	($\times 12$)

cm 1 | 2 | 3 | 4 | 5 | *The Complete Homemade Juggling Beanbag Guide* by Joshua Clifton | 15 | 16 | 17 | 18 | 19 |



Equidistant Truncated Icosahedron (32 Panels)

Uses 20 hexagons, 12 pentagons

Pattern sizes are adjusted for corduroy and do not account for gathered seams.
For footbags with gathered seams, try two sizes ($\frac{1}{2}$ " or 25% larger than target diameter.

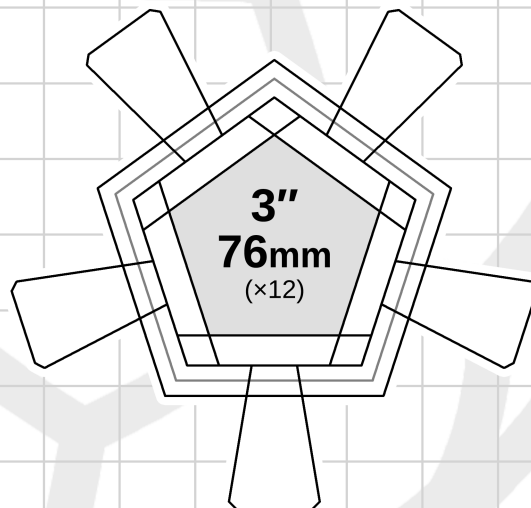
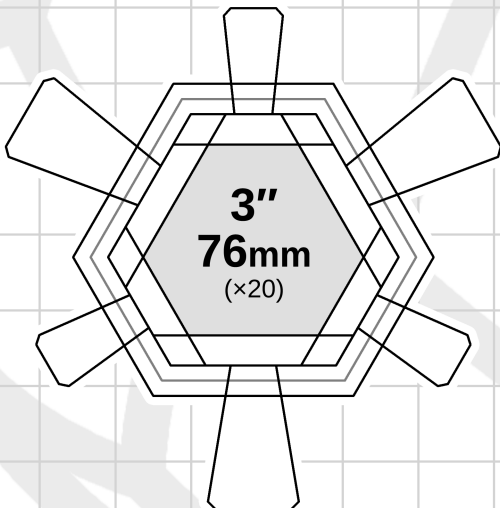
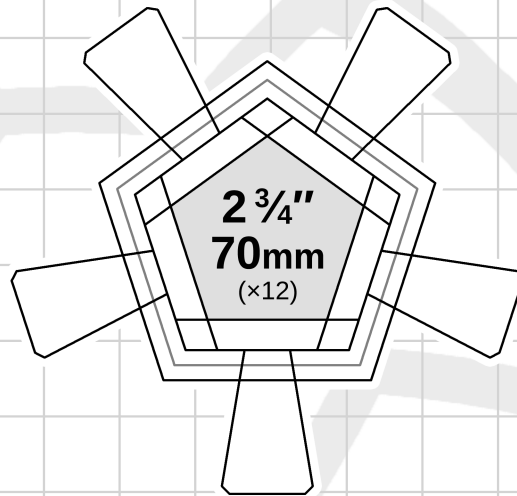
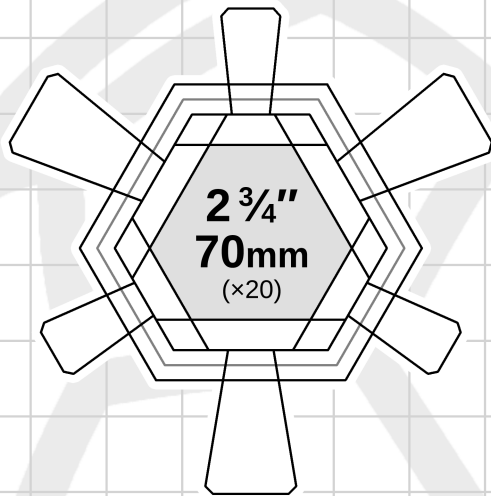



Equidistant Truncated Icosahedron (32 Panels)



Uses 20 hexagons, 12 pentagons

Pattern sizes are adjusted for corduroy and do not account for gathered seams.
For footbags with gathered seams, try two sizes ($\frac{1}{2}$ " or 25% larger than target diameter.

Extra large and versatile patterns for scaling to larger sizes in the Print Dialog (the pent is on the next page). Print each pattern twice if you want both a stitching template and a cutting template (or cut out combo templates). The inner patterns (filled with gray) are the stitching patterns. Each dark pattern outside of those marks a 4mm seam allowance interval (at 100% scaling). Use those or the lighter, half-intervals between them to cut out the amount of allowance you want for the cutting templates.

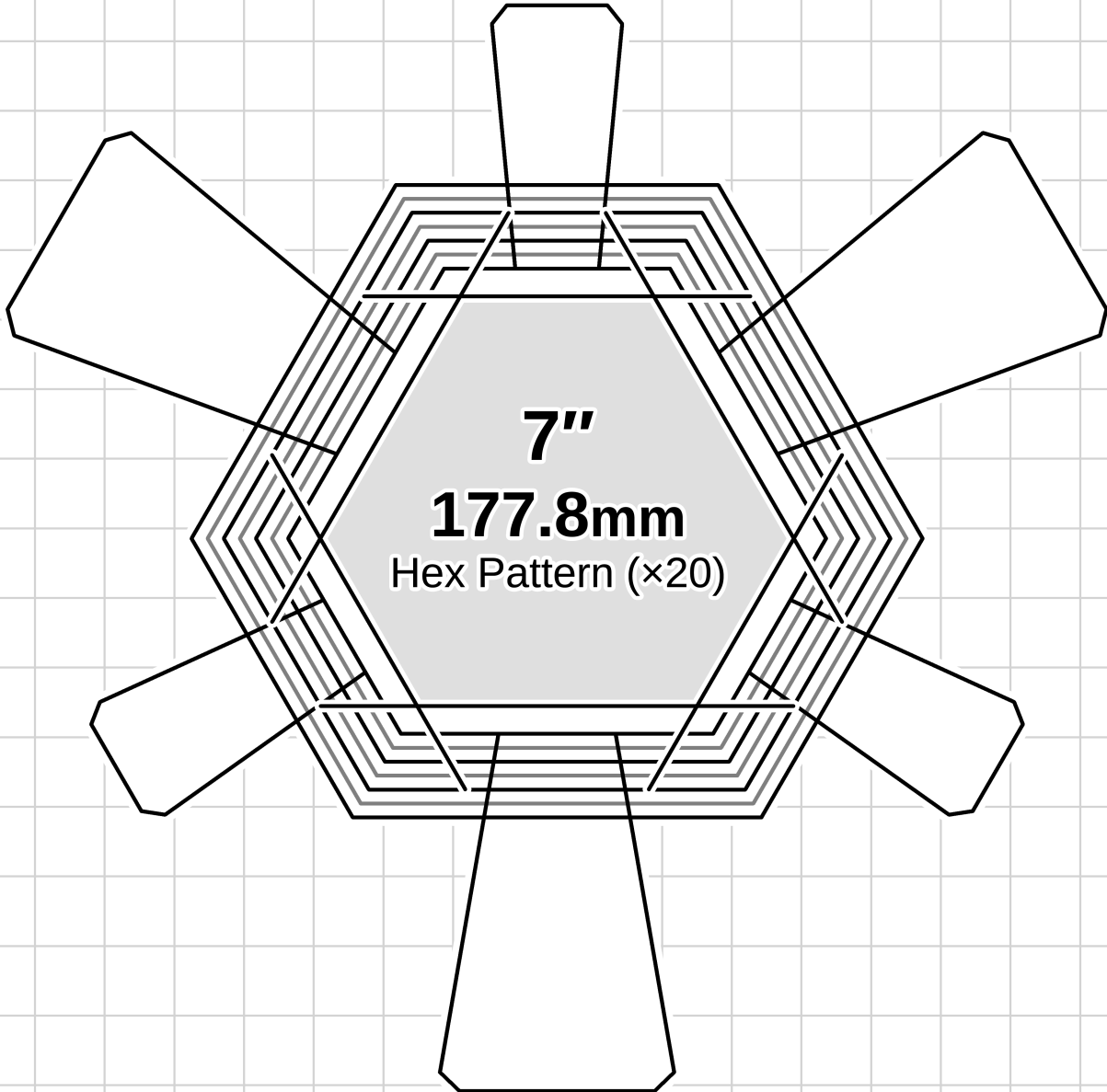



Equidistant Truncated Icosahedron (32 Panels)

Uses 20 hexagons, 12 pentagons

Pattern sizes are adjusted for corduroy and do not account for gathered seams.
For footbags with gathered seams, try two sizes ($\frac{1}{2}$ " or 25% larger than target diameter.

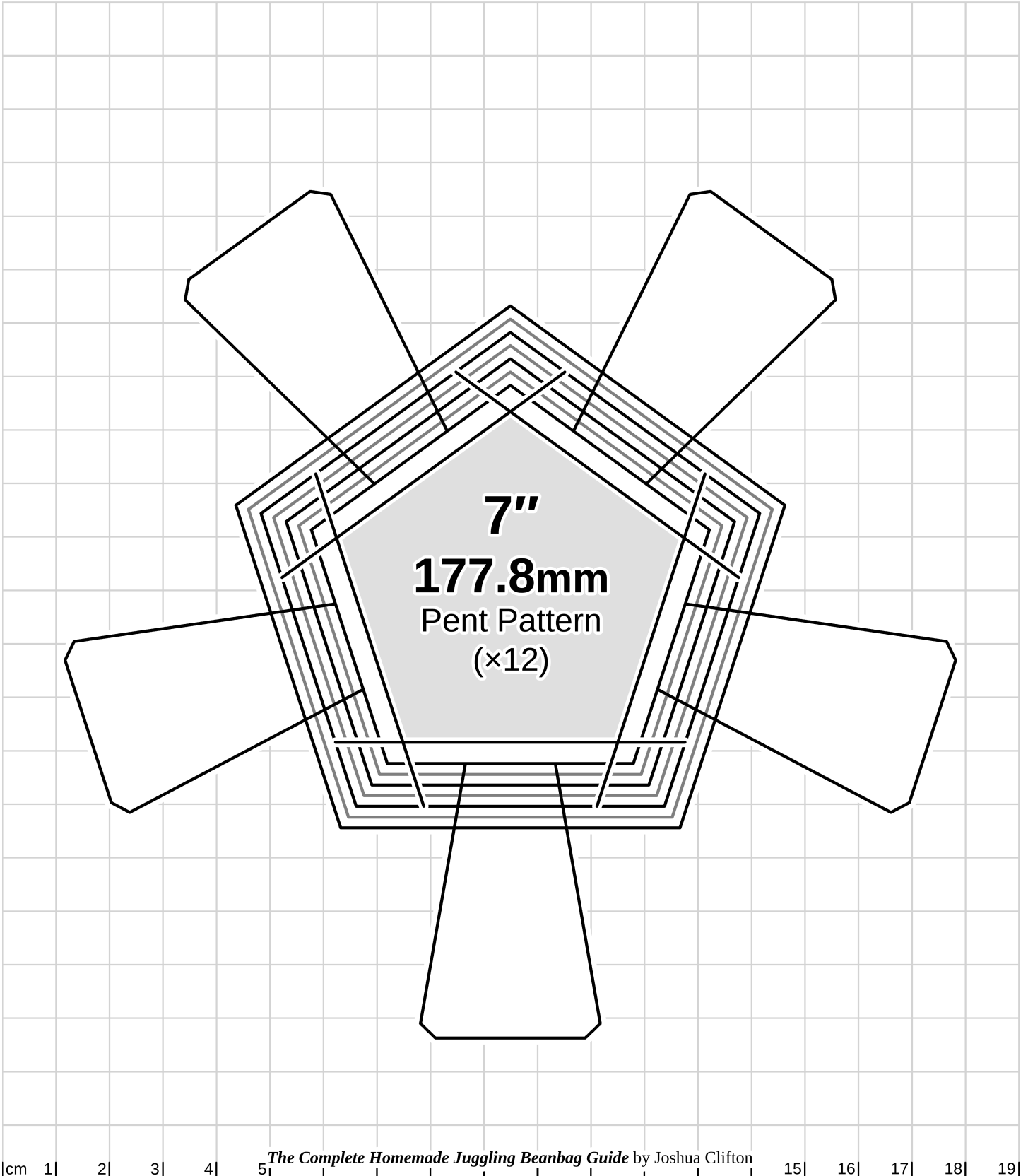



Modified Icosidodecahedron (32 Panels)



14-Panel/Footbag-Style Hexes (Uses 20 hexagons, 12 pentagons)

Pattern sizes are adjusted for corduroy and do not account for gathered seams.

For footbags with gathered seams, try two sizes ($\frac{1}{2}$ " or 25% larger than target diameter.

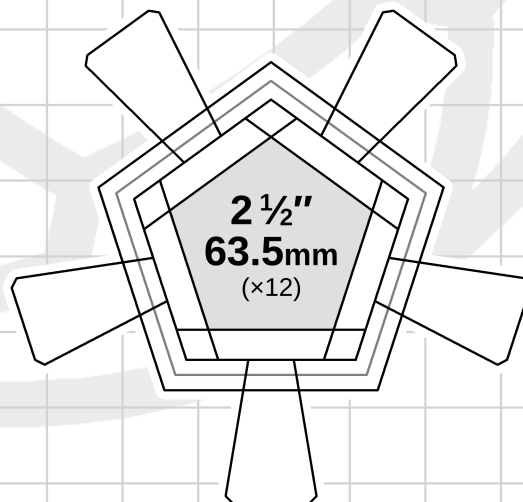
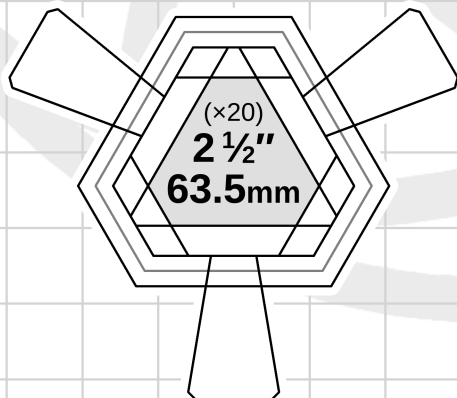
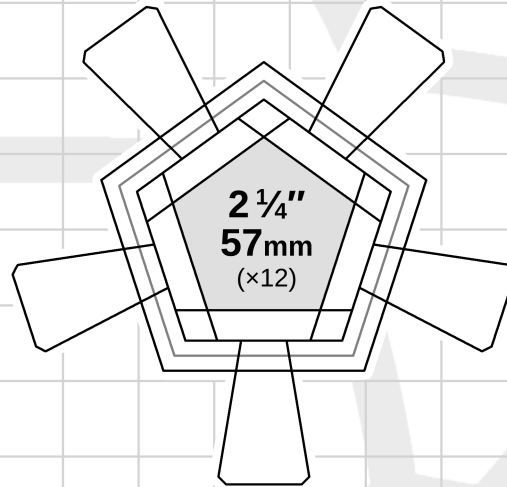
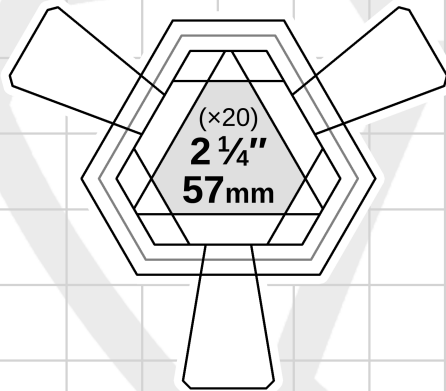
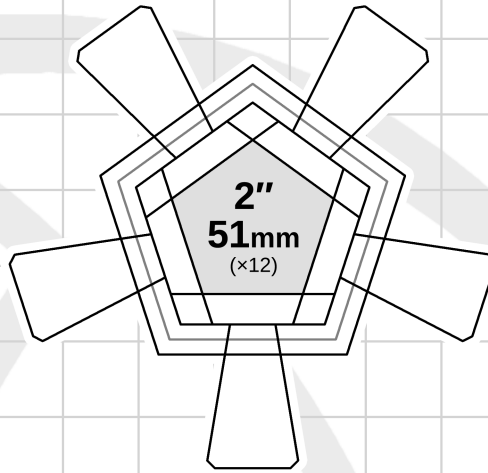
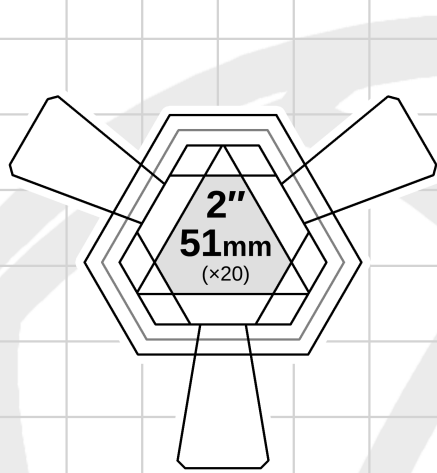



Modified Icosidodecahedron (32 Panels)

14-Panel/Footbag-Style Hexes (Uses 20 hexagons, 12 pentagons)

Pattern sizes are adjusted for corduroy and do not account for gathered seams.

For footbags with gathered seams, try two sizes ($\frac{1}{2}$ " or 25% larger than target diameter.

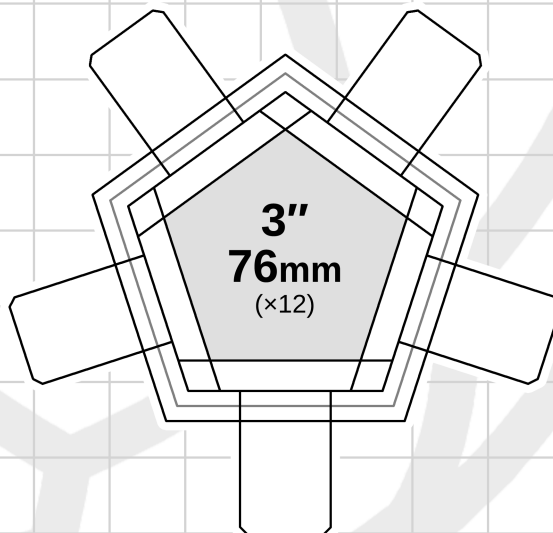
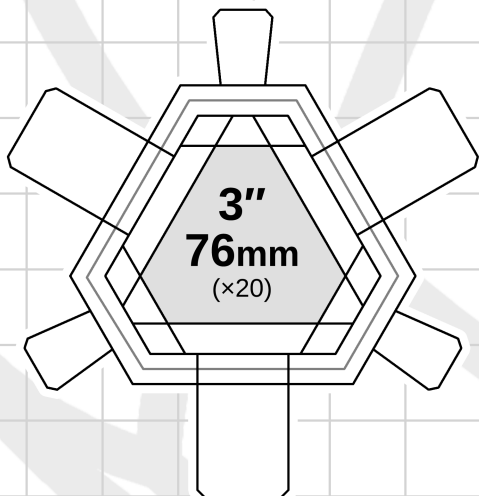
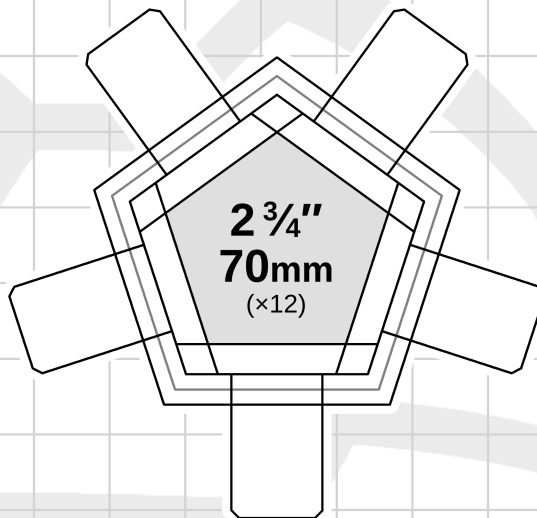
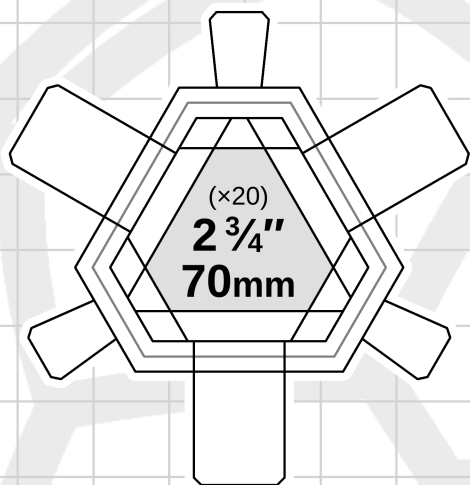



Modified Icosidodecahedron (32 Panels)



14-Panel/Footbag-Style Hexes (Uses 20 hexagons, 12 pentagons)

Pattern sizes are adjusted for corduroy and do not account for gathered seams.

For footbags with gathered seams, try two sizes (1/2") or 25% larger than target diameter.

Extra large and versatile patterns for scaling to larger sizes in the Print Dialog (the pent is on the next page). Print each pattern twice if you want both a stitching template and a cutting template (or cut out combo templates). The inner patterns (filled with gray) are the stitching patterns. Each dark pattern outside of those marks a 4mm seam allowance interval (at 100% scaling). Use those or the lighter, half-intervals between them to cut out the amount of allowance you want for the cutting templates.

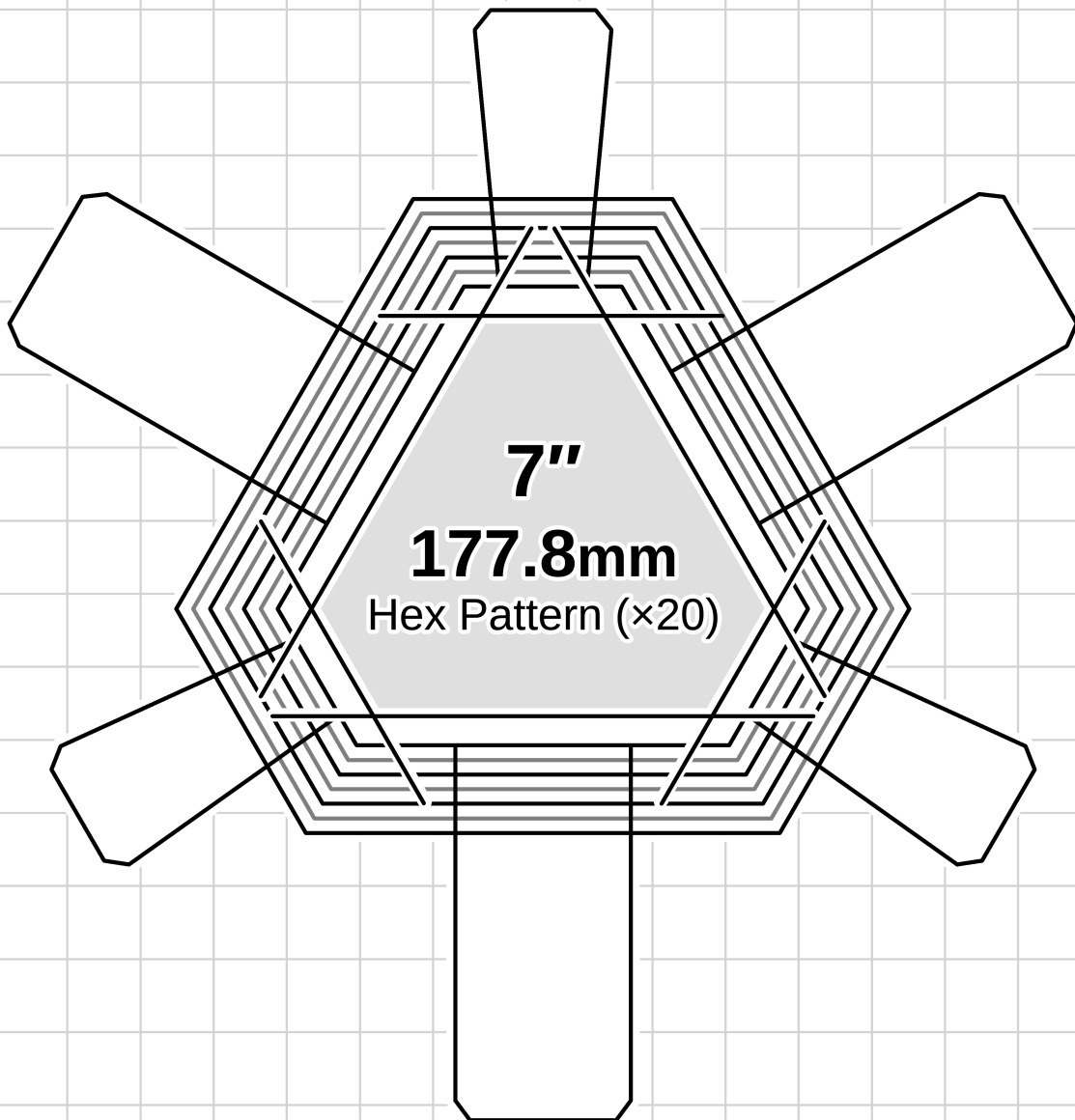



Modified Icosidodecahedron (32 Panels)

14-Panel/Footbag-Style Hexes (Uses 20 hexagons, 12 pentagons)

Pattern sizes are adjusted for corduroy and do not account for gathered seams.

For footbags with gathered seams, try two sizes ($\frac{1}{2}$ " or 25% larger than target diameter.

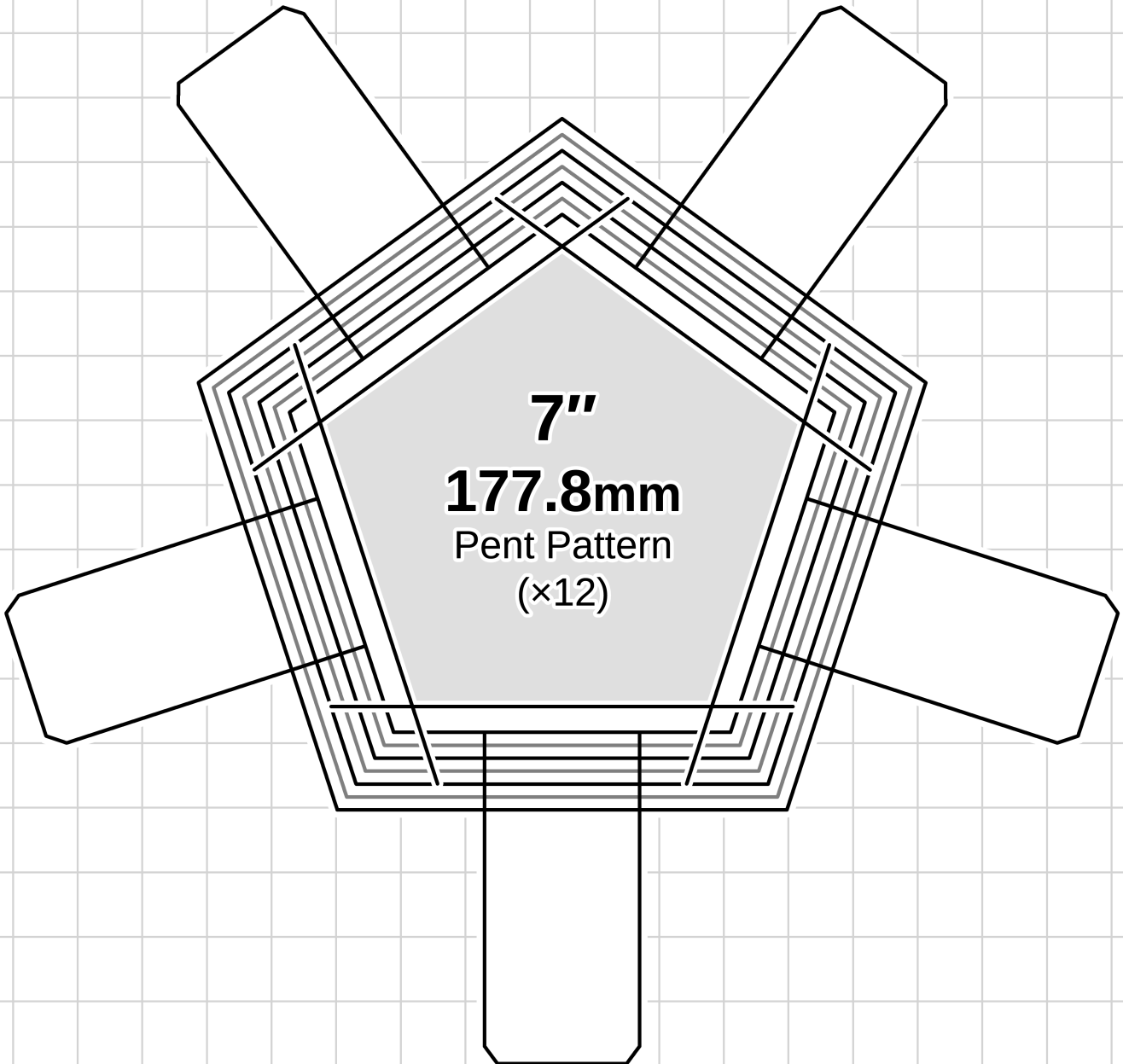



Icosidodecahedron (32 Panels)

Uses 20 triangles, 12 pentagons

Pattern sizes are adjusted for corduroy and do not account for gathered seams.
For footbags with gathered seams, try two sizes ($\frac{1}{2}$ " or 25% larger than target diameter.

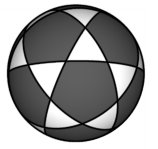

Row	Column	Shape	Size (Inches)	Size (mm)	Quantity
1	1	Triangle	2"	51mm	
1	2	Pentagon	2"	51mm	(x12)
2	1	Triangle	2 1/4"	57mm	
2	2	Pentagon	2 1/4"	57mm	(x12)
3	1	Triangle	2 1/2"	63.5mm	
3	2	Pentagon	2 1/2"	63.5mm	(x12)

cm 1 | 2 | 3 | 4 | 5 | *The Complete Homemade Juggling Beanbag Guide* by Joshua Clifton | 15 | 16 | 17 | 18 | 19 |

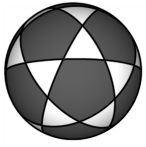

Icosidodecahedron (32 Panels)

Uses 20 triangles, 12 pentagons

Pattern sizes are adjusted for corduroy and do not account for gathered seams.
For footbags with gathered seams, try two sizes ($\frac{1}{2}$ " or 25% larger than target diameter.

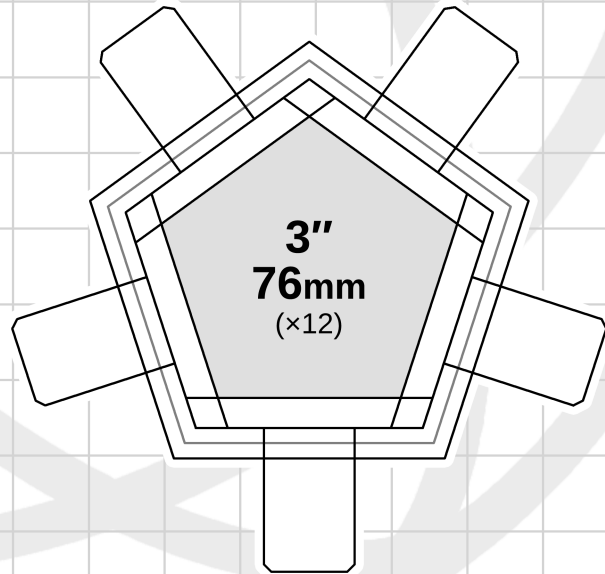
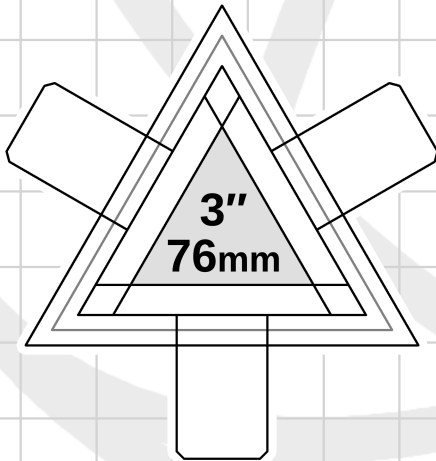
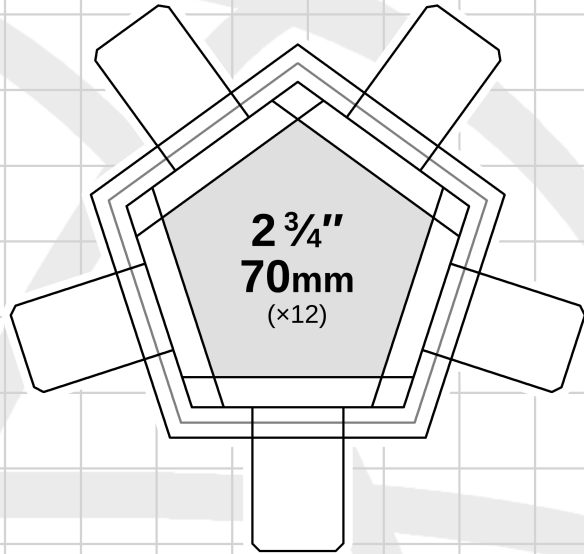
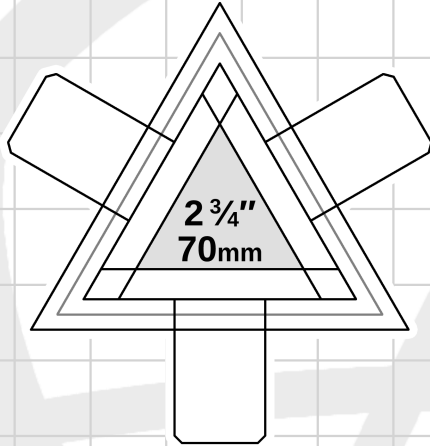
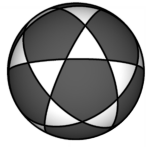

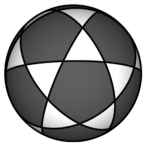

Icosidodecahedron (32 Panels)

Uses 20 triangles, 12 pentagons

Pattern sizes are adjusted for corduroy and do not account for gathered seams.
For footbags with gathered seams, try two sizes ($\frac{1}{2}$ " or 25% larger than target diameter.

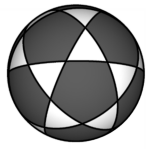

Extra large and versatile patterns for scaling to larger sizes in the Print Dialog (the pent is on the next page). Print each pattern twice if you want both a stitching template and a cutting template (or cut out combo templates). The inner patterns (filled with gray) are the stitching patterns. Each dark pattern outside of those marks a 4mm seam allowance interval (at 100% scaling). Use those or the lighter, half-intervals between them to cut out the amount of allowance you want for the cutting templates.

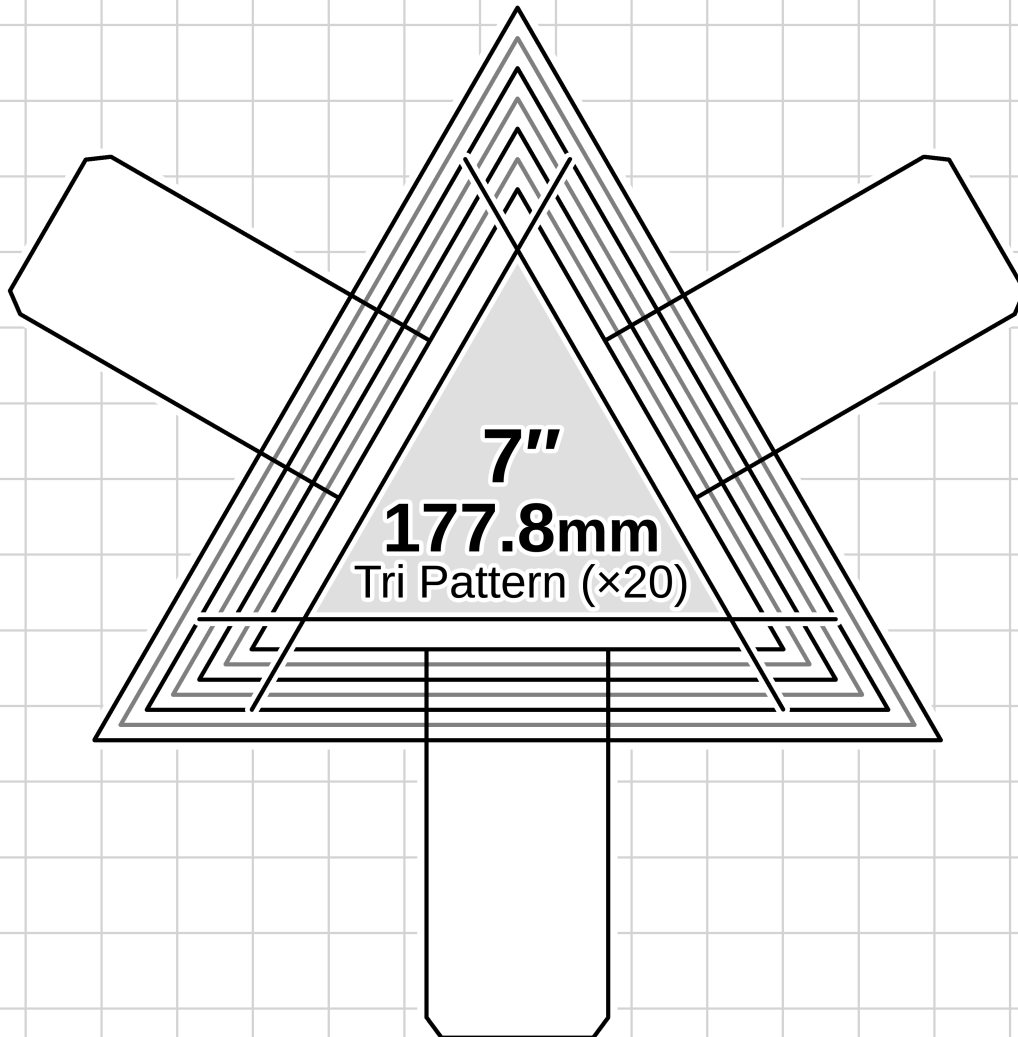

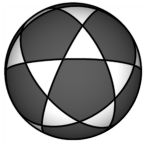

Icosidodecahedron (32 Panels)

Uses 20 triangles, 12 pentagons

Pattern sizes are adjusted for corduroy and do not account for gathered seams.
For footbags with gathered seams, try two sizes ($\frac{1}{2}$ " or 25% larger than target diameter.

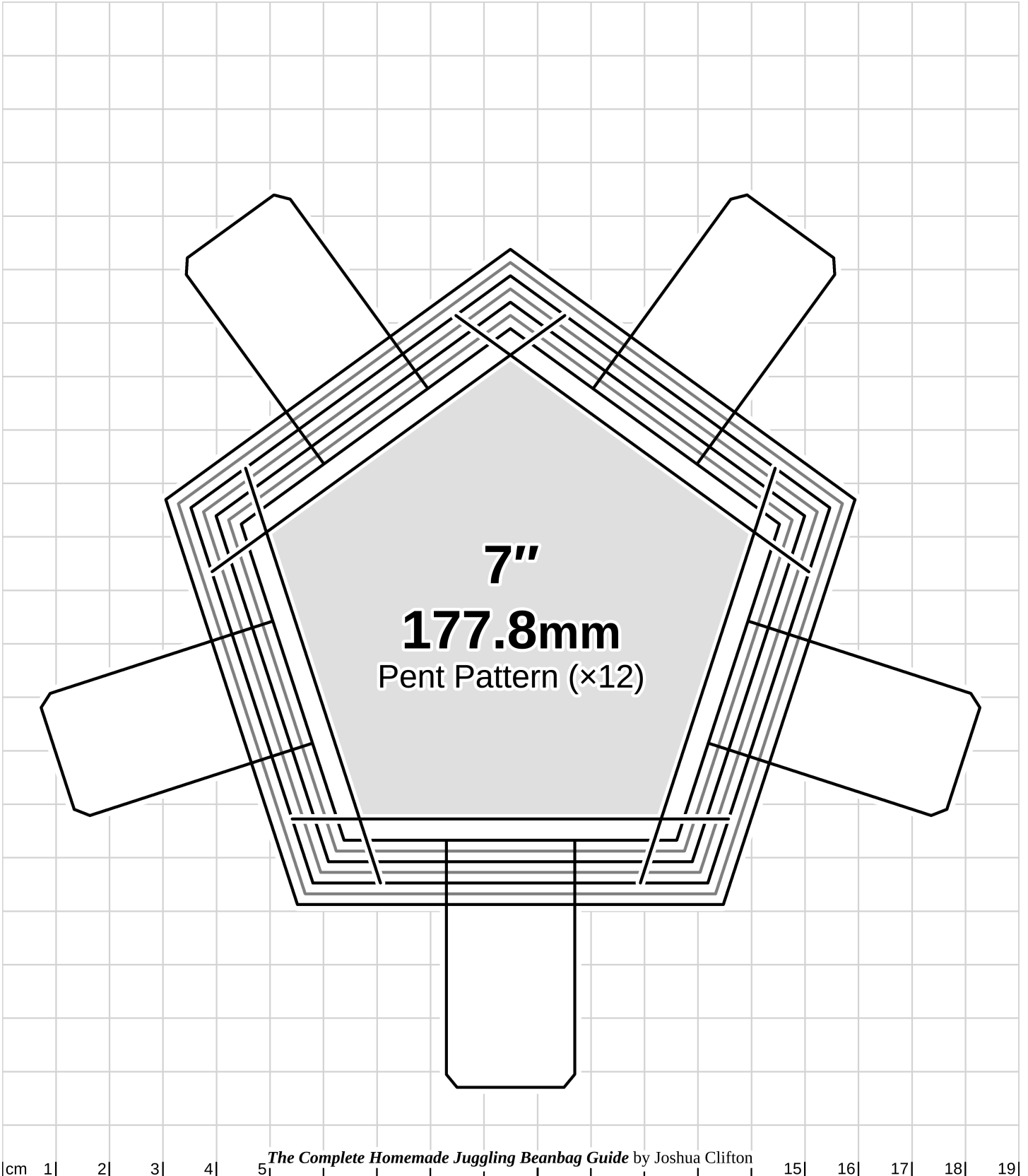
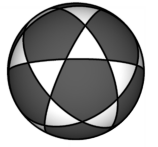



Truncated Icosahedron/Soccer Ball (32 Panels)



Uses 20 equilateral hexagons, 12 pentagons

Pattern sizes are adjusted for corduroy and do not account for gathered seams.
For footbags with gathered seams, try two sizes ($\frac{1}{2}$ ") or 25% larger than target diameter.

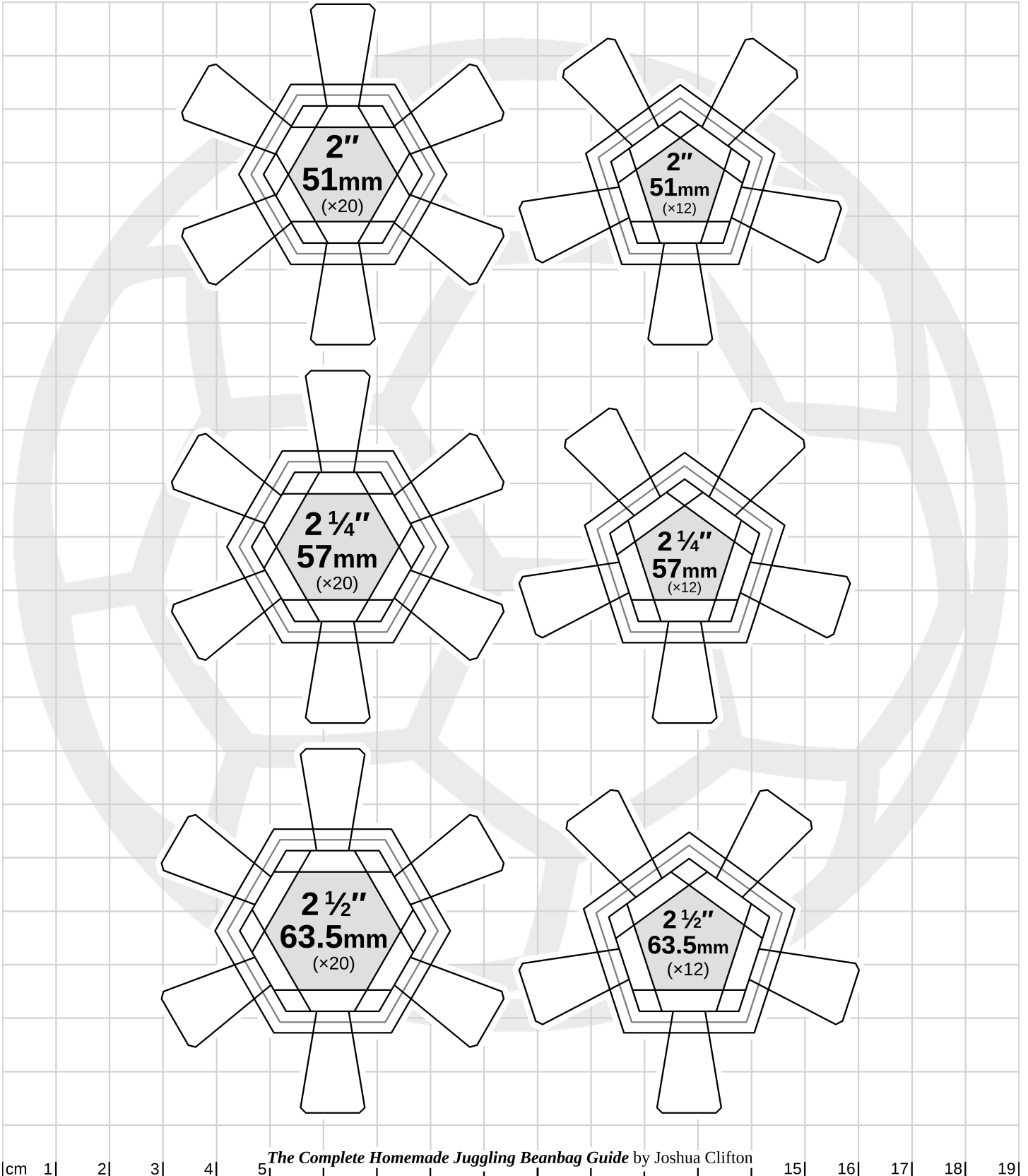



Truncated Icosahedron/Soccer Ball (32 Panels)



Uses 20 equilateral hexagons, 12 pentagons

Pattern sizes are adjusted for corduroy and do not account for gathered seams.
For footbags with gathered seams, try two sizes ($\frac{1}{2}$ " or 25% larger than target diameter.

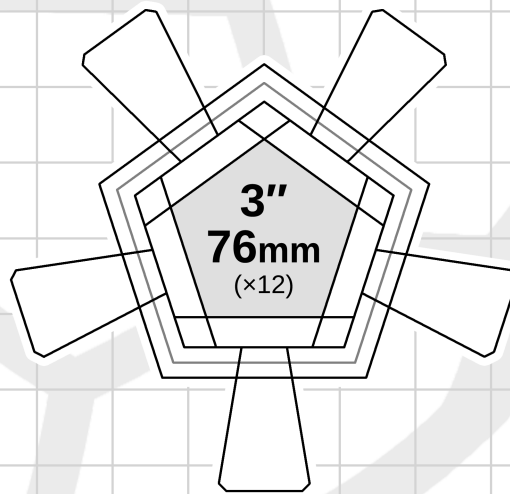
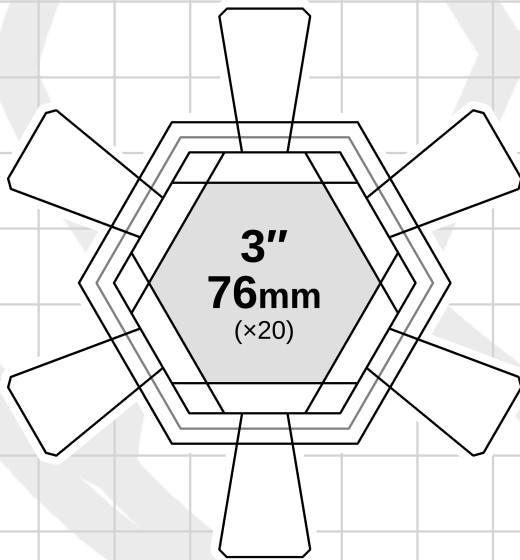
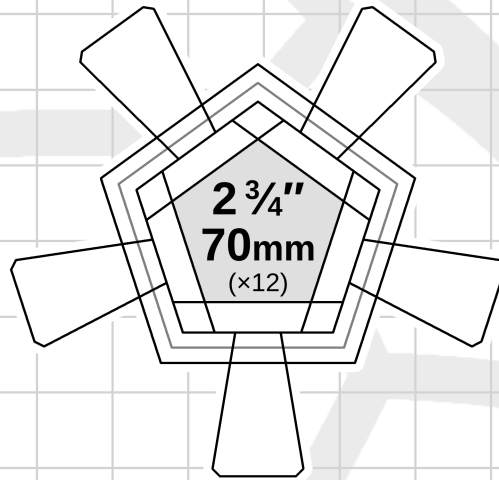
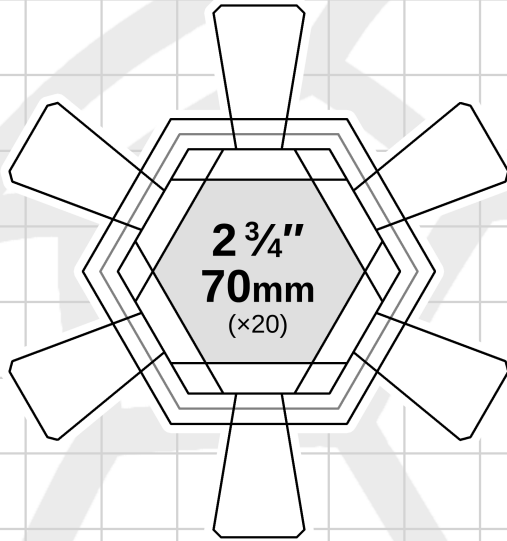



Truncated Icosahedron/Soccer Ball (32 Panels)



Uses 20 equilateral hexagons, 12 pentagons

Pattern sizes are adjusted for corduroy and do not account for gathered seams.
For footbags with gathered seams, try two sizes ($\frac{1}{2}$ ") or 25% larger than target diameter.

Extra large and versatile patterns for scaling to larger sizes in the Print Dialog (the pent is on the next page). Print each pattern twice if you want both a stitching template and a cutting template (or cut out combo templates). The inner patterns (filled with gray) are the stitching patterns. Each dark pattern outside of those marks a 4mm seam allowance interval (at 100% scaling). Use those or the lighter, half-intervals between them to cut out the amount of allowance you want for the cutting templates.

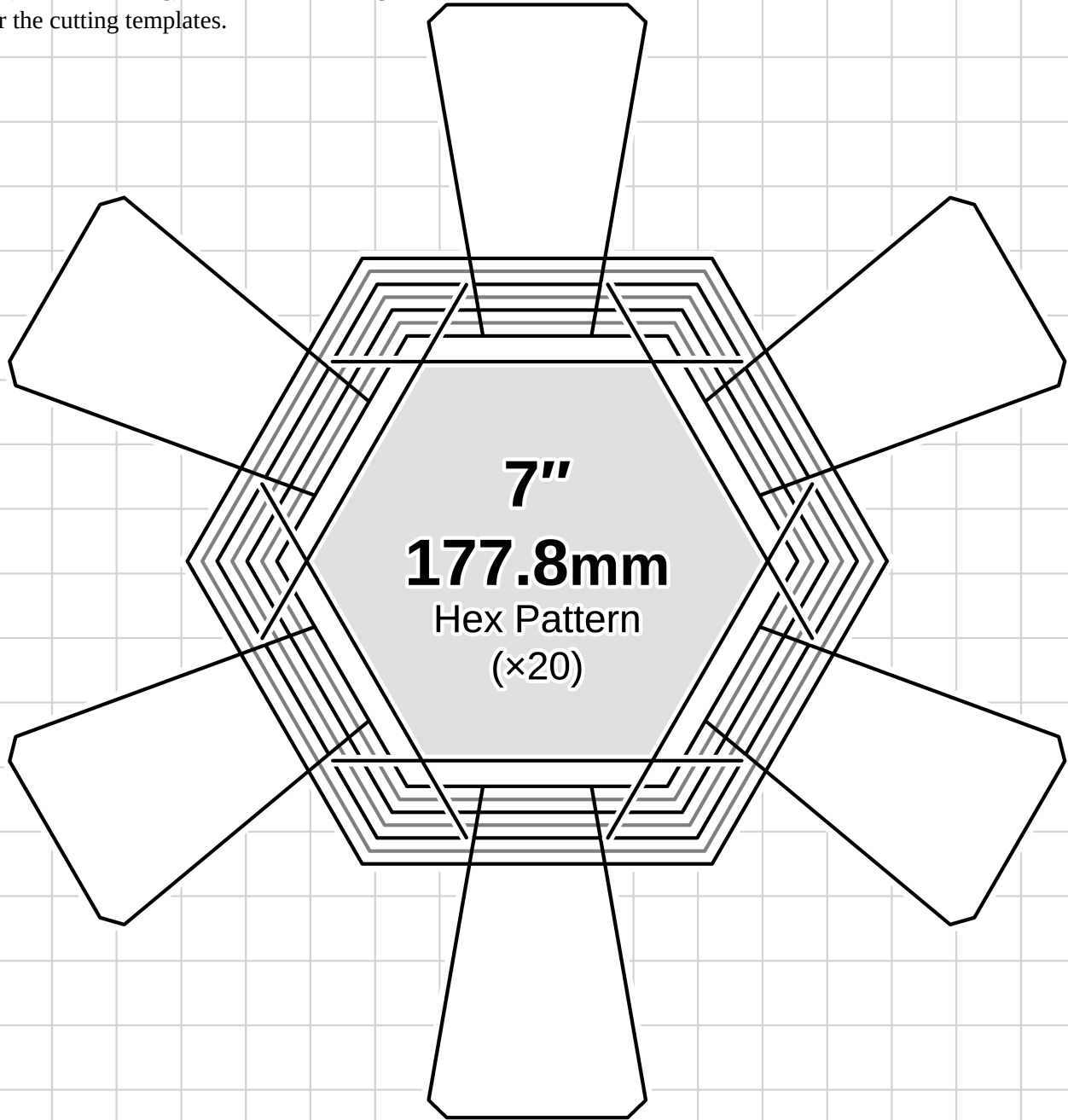



Truncated Icosahedron/Soccer Ball (32 Panels)

Uses 20 equilateral hexagons, 12 pentagons

Pattern sizes are adjusted for corduroy and do not account for gathered seams.
For footbags with gathered seams, try two sizes ($\frac{1}{2}$ ") or 25% larger than target diameter.

